

# Route Access Standard

## Appendix A

### Rolling Stock Outlines and Loading Requirements

#### Applicability

---

ARTC Network Wide
SMS

#### Publication Requirement

---

External Only
---------------

#### Primary Source

---

--

#### Document Status

Version #	Date Reviewed	Prepared by	Reviewed by	Endorsed	Approved
1.2	19 Jun 20	Operations Standards Manager	Stakeholders	Manager Standards	GM Technical Standards

#### Amendment Record

<b>Amendments to the RAS are published at the following link</b>
<a href="https://www.artc.com.au/uploads/RAS_Amendments_Register.xlsx">https://www.artc.com.au/uploads/RAS_Amendments_Register.xlsx</a>
Version 1.1 issued for alterations to rolling stock outline diagrams
Version 1.2 issued for alterations to rolling stock outline diagrams

© Australian Rail Track Corporation Limited (ARTC)

#### Disclaimer

This document has been prepared by ARTC for internal use and may not be relied on by any other party without ARTC's prior written consent. Use of this document shall be subject to the terms of the relevant contract with ARTC.

ARTC and its employees shall have no liability to unauthorised users of the information for any loss, damage, cost or expense incurred or arising by reason of an unauthorised user using or relying upon the information in this document, whether caused by error, negligence, omission or misrepresentation in this document.

**This document is uncontrolled when printed.**

Authorised users of this document should visit ARTC's intranet or extranet ([www.artc.com.au](http://www.artc.com.au)) to access the latest version of this document.

# Appendix A – Rolling Stock Outline and Loading Requirements

## Contents

<b>1</b>	<b>General Requirement for Outlines on the ARTC Network .....</b>	<b>3</b>
1.1	Definitions.....	3
1.2	General Requirements .....	3
<b>2</b>	<b>Allowable Static Rolling Stock Outlines .....</b>	<b>4</b>
2.1	Kinematic Out Lines .....	5
2.2	Unrestricted Maximum Rolling Stock Outlines.....	5
<b>3</b>	<b>Other Permitted Vehicle Proportions to Meet Equivalent Swept Path of Rollingstock Outlines ...</b>	<b>5</b>
<b>4</b>	<b>Curve Negotiation.....</b>	<b>5</b>
<b>5</b>	<b>Signalling and Train Detection Interface .....</b>	<b>6</b>
<b>6</b>	<b>Loading Outlines and Operating Requirements .....</b>	<b>7</b>
6.1	Freight Loading Diagrams.....	7
6.2	Loading Requirements .....	7
6.3	Container Loading.....	8
6.4	Centre of Gravity .....	9
6.5	Loading Inspection .....	9
<b>7</b>	<b>Out of Gauge Outlines and Out of Gauge Loading Approvals .....</b>	<b>10</b>
7.1	Out of Gauge to Rolling Stock Outline .....	10
7.2	Out of Gauge Loading Movements and Train Paths .....	10
7.3	Out of Gauge Trains.....	10
<b>8</b>	<b>Testing of Vehicles to Outlines and Other Requirements.....</b>	<b>11</b>
8.1	Rollingstock Outline Testing.....	11
<b>9</b>	<b>Rolling Stock Outline and Loading Diagrams .....</b>	<b>11</b>

# 1 General Requirement for Outlines on the ARTC Network

## 1.1 Definitions

Term or acronym	Description
In Gauge	Any vehicle or vehicle plus loading outline that is inside the height width and lengths for the relevant corridors for permissible rollingstock outlines on the ARTC Network. (refer ARTC Route Access Standard)
Out of Gauge	Any vehicle or vehicle plus loading including any centre throw or end swing, that exceeds the in-gauge limits for permissible rollingstock outlines on the ARTC Network. (refer ARTC Route Access Standard)
RISSB	Rail Industry Safety and Standards Board

## 1.2 General Requirements

Rolling stock and track maintenance machines shall be constructed, loaded and operated to conform to the limiting outline for the corridor as listed in Table A1.

This document should be used in conjunction with “AS5707 - Rolling Stock Outlines” and the RISSB “Code of Practice for Loading of Rail Freight”.

The following conditions apply to all rolling stock outlines on the ARTC Network:

- The clearances above rail shall be maintained under all conditions of loading, wear and operation as measured on level track free of defects.
- Allowance shall be made for the maximum deflection of load carrying springs or other suspension systems and the maximum permissible wear of wheels, bogie components, centre plates (both laterally and vertically), etc. through the full life cycle of the asset.
- When modified, the vehicle dimensions and characteristics will be assessed against the appropriate Reference Rolling Stock Outline.
- Vehicles shall be able to negotiation a 100 m radius horizontal curve.
- The clearance above rail of the vehicle body and any fittings or attachments shall permit transit over a summit (convex curve) of 300m radius.
- Considerations for greater clearances above rail may be required for rolling stock features such as discharge doors, tank car outlets, brake equipment etc.
- The bottoms of side-hung doors which swing outwards and of other door types which extend laterally beyond the outline when open, shall be a minimum of 1120 mm above the rail under all conditions.
- The outline diagrams illustrate the limiting dimensions for conventional bogies. Articulated vehicle bogies shall also comply with the requirements of this section including the distance between the bogie pivots to the end of the vehicle. The relation between bogie centre distance and end overhang shall satisfy the L/V requirements specified for the ARTC Network.
- Flat, well, skeletal and open cars are defined by the maximum width, whereas the vehicle height for the rolling stock outline is defined by the load being carried. Operators will develop procedures for managing all loading is within the permissible outline by corridor as specified in

this document. Loading restraints will be used where necessary to ensure loads are maintained within the rolling stock outlines.

- Expendable items outside of the reference rolling stock outline that has low consequences in the event of an infringement can be treated as an expendable item as defined in AS7507 - Rolling Stock Outlines – Section 4 .2 Expendable Items.
- The static rolling stock outline should be met by the rolling stock under all maintenance and loading conditions:
  - Clearances shall be measured under full allowable load, with fully worn spring and suspension systems condition and minimum wheel diameter.
  - Clearances shall also be measured under tare weight, with new springs and suspension systems, and full allowable wheel diameter.
- Operators and rolling stock owners shall maintain data and operating procedures for what plate each rolling stock classification meets and where it can operate and any associated operating restrictions for each class of vehicle.
- Operators shall have procedures for managing all loads to meet the loading requirements and outlines as specified in section 6 and in accordance with the RISSB “Code of Practice for Loading of Rail Freight”.

## 2 Allowable Static Rolling Stock Outlines

This section defines the rolling stock outlines to operate over the ARTC Network. Refer to Section 9 for the Static Rolling Stock Outline Drawings A1.1 through A1.16.

Locations where each of these rolling stock outlines are permitted to operate is detailed in Section 5 of the Route Access Standard (RAS) General Information.

**Table A1 – Permitted Rolling Stock Outline on the ARTC Network**

Diagram	Rolling Stock Static Outlines	RISSB Ref Vehicle #
A1.1	Rolling Stock Interstate Outline Plate A	RV1
A1.2	Rolling Stock Interstate Outline Plate B	RV2
A1.3	Rolling Stock Interstate Outline Plate C	RV3
A1.4	Rolling Stock Interstate Outline Plate D	RV4
A1.5	Rolling Stock Interstate Outline Plate E1	Note 1
A1.6	Rolling Stock Interstate Outline Plate F1	Note 1
A1.7	Rolling Stock Interstate Outline Plate F2	Note 1
A1.8	Rolling Stock Interstate Outline Plate H	Note 1
A1.9	Rolling Stock Outline Plate CY4150	RV7
A1.10	Rolling Stock Outline Plate CZ	RV8
A1.11	Rolling Stock Outline Plate Narrow Non-Electric (NNE)	RV21
A1.12	Rolling Stock Outline Plate NSW Narrow Container (NC)	RV23
A1.13	Rolling Stock Outline Plate NSW Narrow Square (NS)	RV24
A1.14	Rolling Stock Outline Plate NSW Inter System (IS)	RV25
A1.15	Rolling Stock Outline Plate NSW Narrow Hopper (NH)	RV26
A1.16	Rolling Stock Outline Plate NSW Double Stacking (DS)	RV9

**Notes:**

“RV#” – RISSB Reference Vehicle number as per AS7507 as published in 2017

1: These plates are currently not published in RISSB AS7507 as published in 2017

## 2.1 Kinematic Out Lines

The kinematic outline consists of the static outline, rolling stock dynamics and dynamics in response to track irregularity. The applicable dynamic rollingstock limits and track tolerances are tabulated in ARTC's Code of Practice Section 7 – Clearances.

## 2.2 Unrestricted Maximum Rolling Stock Outlines

Diagrams A1.1, Rolling Stock Outline Interstate Plate A, and A1.11 Plate Narrow Non-Electric (NNE), illustrate the limiting outline for rolling stock intended for unrestricted intersystem operation on all standard and broad-gauge lines.

For unrestricted interchange operation on the ARTC network on all standard and broad-gauge corridors profile plate A and Narrow Non-Electric (NNE), cannot be infringed in anyway.

## 3 Other Permitted Vehicle Proportions to Meet Equivalent Swept Path of Rollingstock Outlines

The rolling stock outlines for each diagram A1.1 to A1.16 have been based on the bogie centres and end overhang as indicated for each diagram, for which versine and end swing (centre and end throw) are approximately equal. Other vehicle proportions are permitted provided that the vehicle does not extend beyond the swept envelope generated by the base vehicle. The distance between the bogie pivots shall not be increased above that shown on the diagrams unless a reduction is made in the body width dimensions to compensate for the increased centre and end throws on a horizontal curve of 100m radius and a vertical curve on a 300m radius.

In the case of certain rolling stock, track maintenance or construction machines, ARTC may give approval to exceed the maximum overhang indicated with operational conditions.

For vehicles with bogie centres less than the base dimension shown on each outline, the maximum width is that given on the outline diagram.

For vehicles with bogie centres in excess of the base dimension shown on each outline, the maximum width is determined as per methodology in "AS7507 -Rolling Stock Outlines" ensuring the new or modified vehicle fits within the swept path of the reference outline. Noting that reduction of kinematics cannot compensate for exceeding the reference rollingstock static outline.

Methodology used for determining the rollingstock dimensions for alternate vehicle proportions for new or modified vehicles will be presented to ARTC on registering vehicles.

## 4 Curve Negotiation

In addition to the dimensional outline, vehicles shall also comply with the requirements for negotiating curves through a static vehicle swing test.

All freight vehicles shall be designed and constructed to negotiate the horizontal and vertical curves specified in AS7509 Dynamic Behaviour – Sections:

- Horizontal and Vertical Curve Negotiation,
- and Transition Curve Negotiation.

## 5 Signalling and Train Detection Interface

To ensure train safety at converging tracks and at clearance points, Operators shall ensure the distance from the front or end of a train (headstock) to the nearest axle centre does not exceed 3 metres.

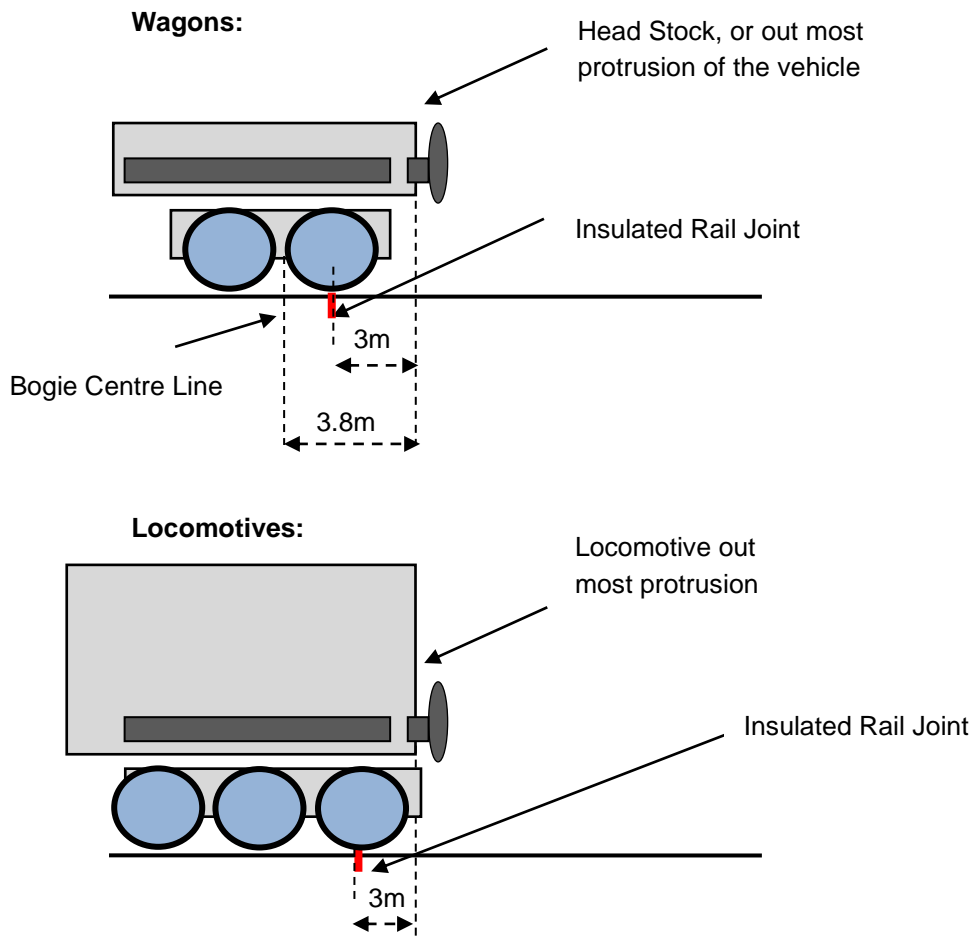

## 6 Loading Outlines and Operating Requirements

### 6.1 Freight Loading Diagrams

Operators shall comply with the loading restrictions specified in the appropriate loading diagram and corresponding area of operation map. Table A2 lists all the Loading Outline Diagrams as illustrated in section 9. Loading outside of the arrangements as illustrated in the diagrams for areas of operation should apply for an out of gauge loading in accordance with section 7.

**Table A2 – Loading Outline Diagrams for the ARTC Network**

Figure	Loading Outline Diagram
A2.1	Maximum Loading Dimensions for Loose Loads for Unrestricted Operation Throughout the ARTC Network
A2.2	Maximum Standard Loading Dimension for Motor Vehicles on Motorail Wagons for Unrestricted Operation Throughout the ARTC Network
A2.3	Maximum Container Loading for Unrestricted Operation Throughout the ARTC Network
A2.4	Maximum Container Loading to meet Plates C, D, NC, NS, and IS
A2.5	Double Stacking of Containers to meet Plate F2
A2.6	Double Stacking of Containers to Meet Plate F1
A2.7	Double Stacking of Containers to Meet Plate E1
A2.8	4220 mm High Maximum Container Loading for Specified Corridors in NSW
A2.9	Maximum Container Loading from Melbourne to Albury
A2.10	Maximum Container Loading from Adelaide to Melbourne
A2.11	Maximum Container Loading from Maroona to Portland & Albion to Jacana
A2.12	Maximum Rolling Stock Outline for ex WA Wheathoppers (WW class)
A2.13	Maximum Loading Dimension for Motor Vehicles on Motorail Wagons from Anzac Highway Bridge (Adelaide) to Regency Road Bridge

### 6.2 Loading Requirements

The retention and proper configuration of loading in or on rail vehicles is a critical issue for safe transit on the ARTC Network. All loads shall be adequately loaded, restrained and secured within containers and to the rolling stock.

Following are additional loading requirements that apply on the ARTC Network:

- Operators shall construct trains of vehicles loaded without exceeding applicable:
  - axle load limits considering weight distribution does not exceed the axle load limit for the intended route of operation,
  - and fits with the loading outline for the intended area of operation
- Containers shall be placed on wagons subject to:
  - Operators ensuring that loading is to be evenly distributed on the wagon with even distribution of loading between bogies
  - the difference between adjacent bogies on a wagon or multipack does not exceed 20 tonne
  - open wagons are free of loose items (e.g. dunnage before loading).
- Loading shall be secured to prevent movement during transit due to train and vehicle dynamic forces generated by deceleration, acceleration, track dynamics and curving.
- Securing devices shall be correctly selected, protected against working loose, falling off or trailing from the wagon en-route, or causing uneven load distribution

- Securing devices used shall be maintained in good condition and fit for use on the ARTC Network
- Loading-specific segregation requirements shall be established and practiced (e.g. Dangerous Goods Code)
- Loading shall not protrude more than 150 mm over the headstock of any vehicle
- Locking mechanisms on doors, containers and open vehicles shall be maintained in good condition and fit for use in respect of opening, closing, security and locking

### 6.3 Container Loading

- Operators shall have procedures for managing the loading of containers on vary deck heights so that container heights are within the applicable plate outlines. Refer Loading diagrams A2.3 through A2.11.
- Containers shall be placed on wagons subject to:
  - Operators ensuring that loading is to be evenly distributed within the container
  - even distribution of loading between bogies
  - the difference between adjacent bogies on a wagon or multipack does not exceed 20 tonnes
  - container(s) loaded in open wagons are located, secured centrally and evenly distributed over the bogies
  - open wagon side doors are secured against opening
  - open wagons without side doors are not operated with a vacant container position
  - open wagons are free of loose items (e.g. dunnage before loading).
- Operators shall have procedures in place to manage the double stacking of containers including but not limited to:
  - Full height containers limited to container height not exceeding the overall height limits for area of operation.
  - Half height containers limited to container height not exceeding the overall height limits for area of operation as listed in Table 2.
  - Not exceeding maximum container loading limits
  - Container securement is to all four points by devices in good condition and fit for use on the ARTC Network
  - The lighter container is positioned on top unless the operator has established that an alternative position is compliant with wagon stability standards (axle load both mass & centre of gravity).
- Operators shall have procedures in place to manage the nesting of containers including but not limited to:
  - height above rail level plus nested container base shall conform to the loading outline diagrams for the applicable corridor as per Table 2.
  - where container bases are not secured with twist locks and/or loaded with gates and/or tarps, the load shall conform to Figure A2.1.
  - container base securement is to all four points, by devices in good condition, to each other and to the container wagon.
- Nested container bases (transi-flats) on container wagons shall be subject to:



- height above rail level plus nested container base shall conform to either A2.3 or Figure A2.4 depending on route
- where container bases are not secured with twist locks and/or loaded with gates and/or tarps, the load shall conform to Figure A2.1
- container base securement is to all four points, by devices in good condition, to each other and to the container wagon.

#### 6.4 Centre of Gravity

- Operators will ensure that the centre of gravity is assessed for the correct rollingstock choice to ensure safe transit for the area of operation.
- The position of the loading should be set so that the transverse location of the centre of mass is as close as possible to the track centre-line. The height above rail level of the combined centre of mass of the vehicle and its load shall not exceed 2650 mm on standard gauge or 2900 mm on broad gauge. Note that freight vehicles that are susceptible to overturning due to wind loading, such as those with large side areas (e.g. double-stack container wagons), or those that operate in high wind conditions or areas of the network with cant deficiency or subject to other dynamic effects may require lower centre of mass limits. (Refer RISSB – Loading of Rail Freight)

#### 6.5 Loading Inspection

- Train examination shall ensure integrity of freight loading in respect of security and weight distribution, overloading, and adherence to the maximum loading gauge dimensions, as well as doors being closed.
- Operators shall have procedures for inspecting loads including but not limited to:
  - Load securement and restraint
  - Soundness and effectiveness of retention devices and securing mechanisms that are fit for purpose for the loads being carted
  - Ensure that containers and transflat are within current compliance specifications
  - Load shift in transit and load adjustments
  - Load protection to prevent loss of loose items or materials
  - Dangerous good separation, labelling and notification
  - Non-conforming loads

## 7 Out of Gauge Outlines and Out of Gauge Loading Approvals

### 7.1 Out of Gauge to Rolling Stock Outline

Operators may seek approval to run rolling stock that does not comply with ARTC's rolling stock outline for the corridor they wish to operate. Out of gauge includes any centre or end throw that exceeds the in-gauge limits. The operator shall seek approval from ARTC to run the rolling stock, providing:

- Diagrams of the rolling stock highlighting the areas of infringement on the outline, providing a drawing showing actual cross-section and kinematic tolerances.
- Identification of corridors intended to operate on,
- Design information and intended movement conditions.

ARTC may permit the rolling stock to operate subject to evaluation with potential operating restrictions for that corridor. Operators will have systems in place to manage the approved out of gauge rolling stock ensuring all restrictions are published in their own documentation.

### 7.2 Out of Gauge Loading Movements and Train Paths

Operators seeking to operate an out of gauge load shall follow the process as defined in "OPE-PR-029 - Application for Out of Gauge Train Notice".

ARTC may consider Operator requests for out of gauge loads on a train path as follows:

- For non-divisible loads that cannot be reasonably reduced within the loading outline dimensions to conform to the ARTC structure gauge
- ARTC shall not consider out of gauge loading requests for divisible items only to increase vehicle capacity
- A request for each proposed out of gauge load on a train path shall be submitted to ARTC in accordance with "OPE-PR-029 - Application for Out of Gauge Train Notice".
- If there is any doubt regarding out of gauge loading, it will not be approved by ARTC
- Out of gauge loads shall not operate without authorisation from ARTC
- Out of gauge loading and train path arrangements include acceptability by the receiving system and is to be arranged by the Operator.

### 7.3 Out of Gauge Trains

In considering requests for out of gauge train service subject to published approval conditions, ARTC may impose and advertise special restrictions including, but not limited to:

- train path and route restrictions
- restricted train length
- restricted train speed for grade conditions
- additional operator inspections en-route
- special arrangements for crossing or passing other trains
- special arrangements for crossing other out of gauge loads

- special arrangements for managing interactions with adjacent lines
- special arrangements including piloting and speed restrictions for passing work on track
- out of gauge train arrangements include acceptability by the receiving system
- special arrangements for temporary configuration changes to infrastructure.

## 8 Testing of Vehicles to Outlines and Other Requirements

### 8.1 Rollingstock Outline Testing

The methods outlined in AS7507 - Rolling Stock Outlines shall be used to conducted rollingstock outline tests for:

- Outline physical tests
- Static Outline
- Kinematic Outline
- Swept Outline

## 9 Rolling Stock Outline and Loading Diagrams

### Notes for all diagrams:

- All dimensions are in mm.
- All cross-section dimensions are symmetrical about the vehicle centreline.
- The origin for all horizontal coordinates is the vehicle centreline.
- The origin for all cross-section vertical coordinates is the rail level.

**Figure A1.1 – Rolling Stock Interstate Outline Plate A**

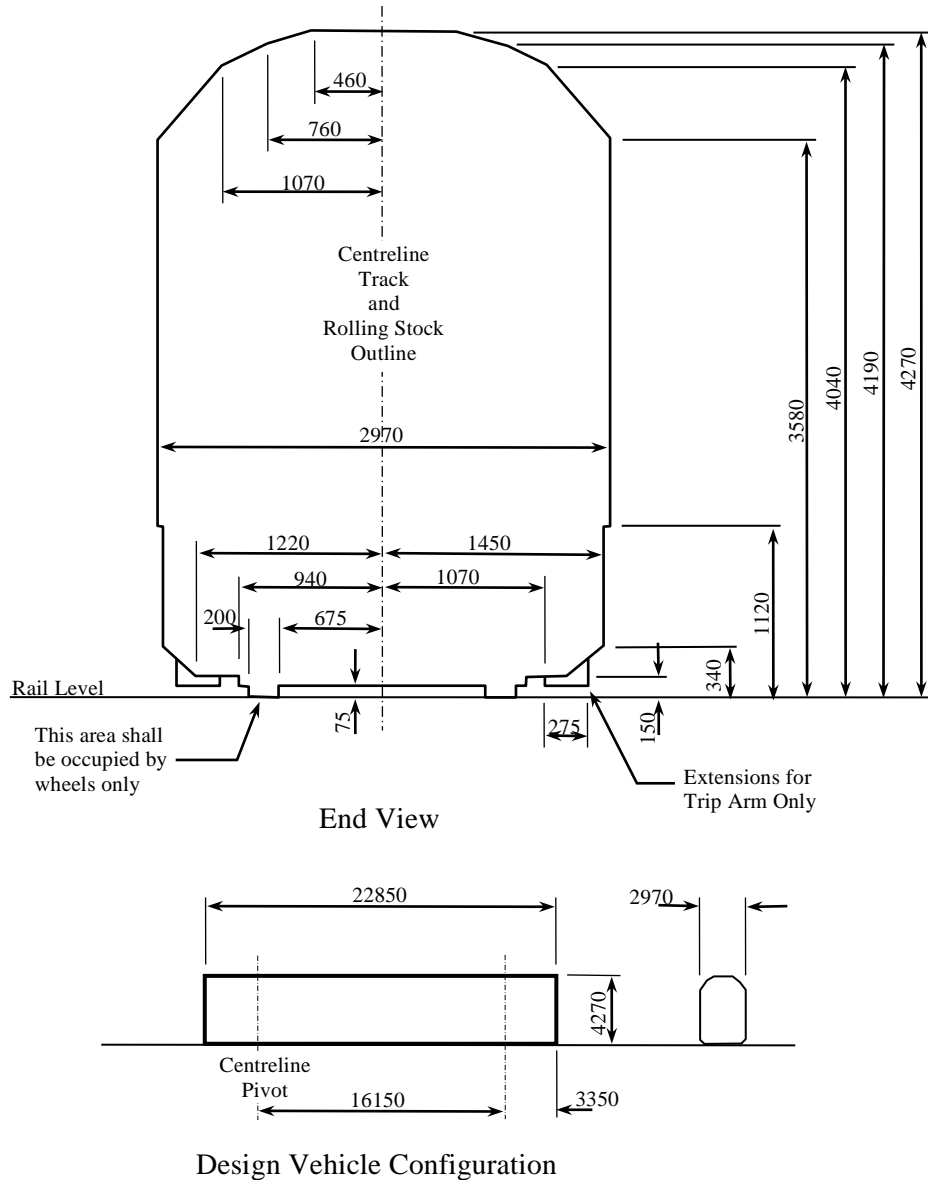

**Notes:**

- [1] *The dimensions between bogie pivots and from bogie pivot to end of body should not be increased unless allowance is made by a reduction in width to compensate for increased centre and end throw on a curve of 100 m radius.*
- [2] *The clearances above rail should be preserved under all conditions of operation, loading and maintenance of a vehicle on level track.*

**Figure A1.2 – Rolling Stock Interstate Outline Plate B**

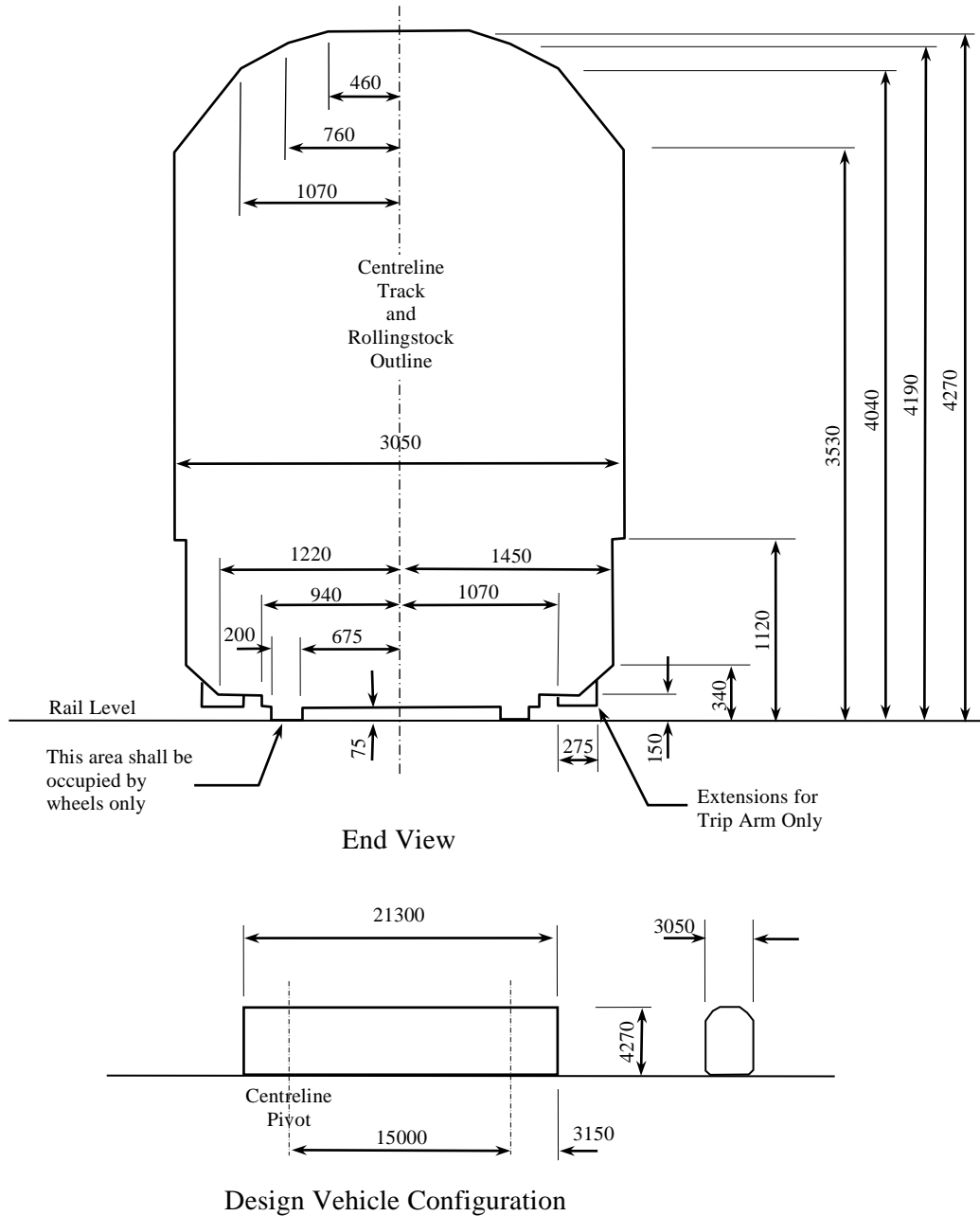

**Notes:**

- [1] *The dimensions between bogie pivots and from bogie pivot to end of body should not be increased unless allowance is made by a reduction in width to compensate for increased centre and end throw on a curve of 100 m radius.*
- [2] *The clearances above rail should be preserved under all conditions of operation, loading and maintenance of a vehicle on level track.*

**Figure A1.3 – Rolling Stock Interstate Outline Plate C**

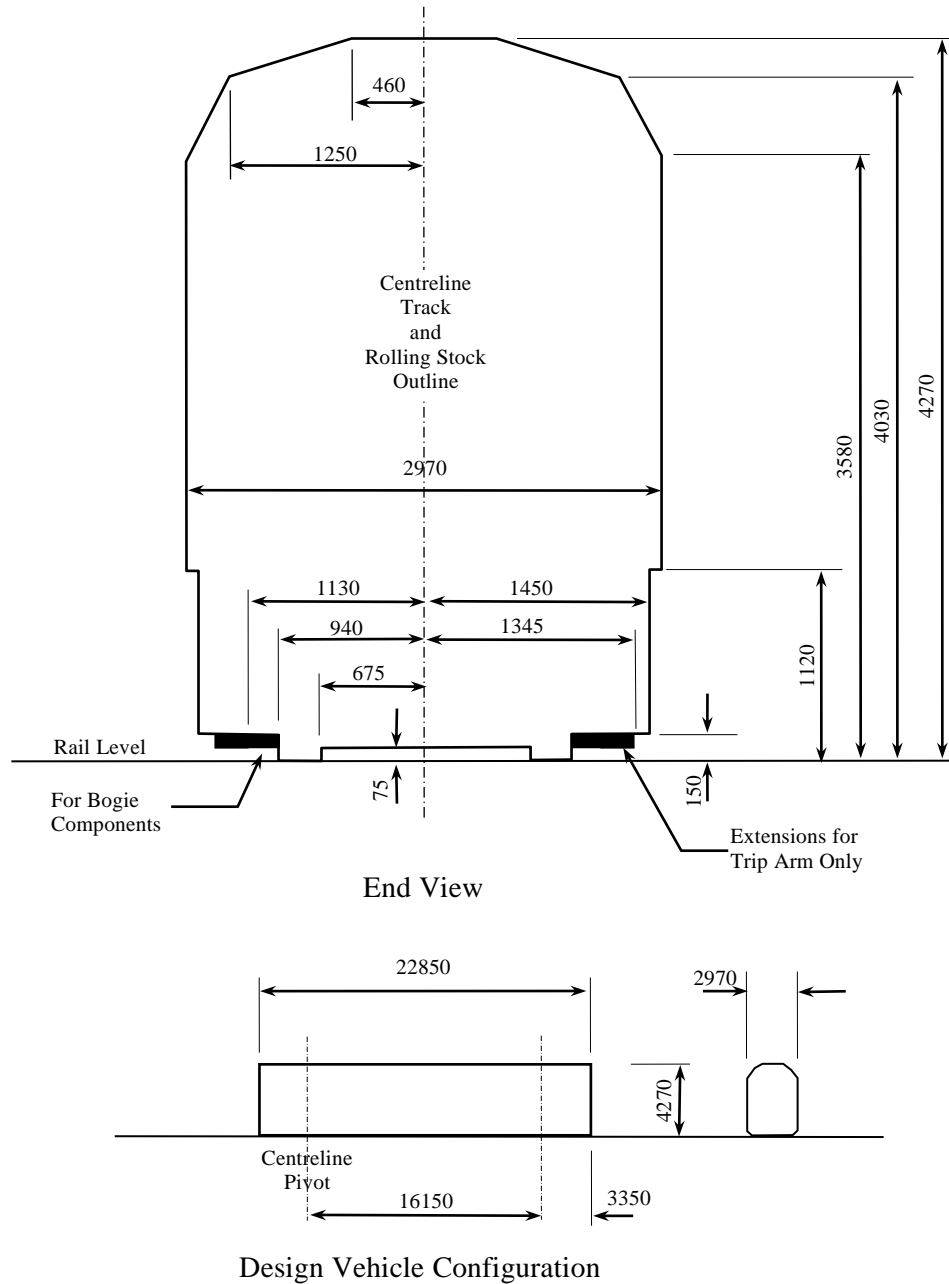

**Notes:**

- [1] *The dimensions between bogie pivots and from bogie pivot to end of body should not be increased unless allowance is made by a reduction in width to compensate for increased centre and end throw on a curve of 100 m radius.*
- [2] *The clearances above rail should be preserved under all conditions of operation, loading and maintenance of a vehicle on level track.*
- [3] *The area outside the wheels, 80mm above rail and 1130mm from the vehicle centre line shall be occupied by bogie components only.*

**Figure A1.4 – Rolling Stock Interstate Outline Plate D**

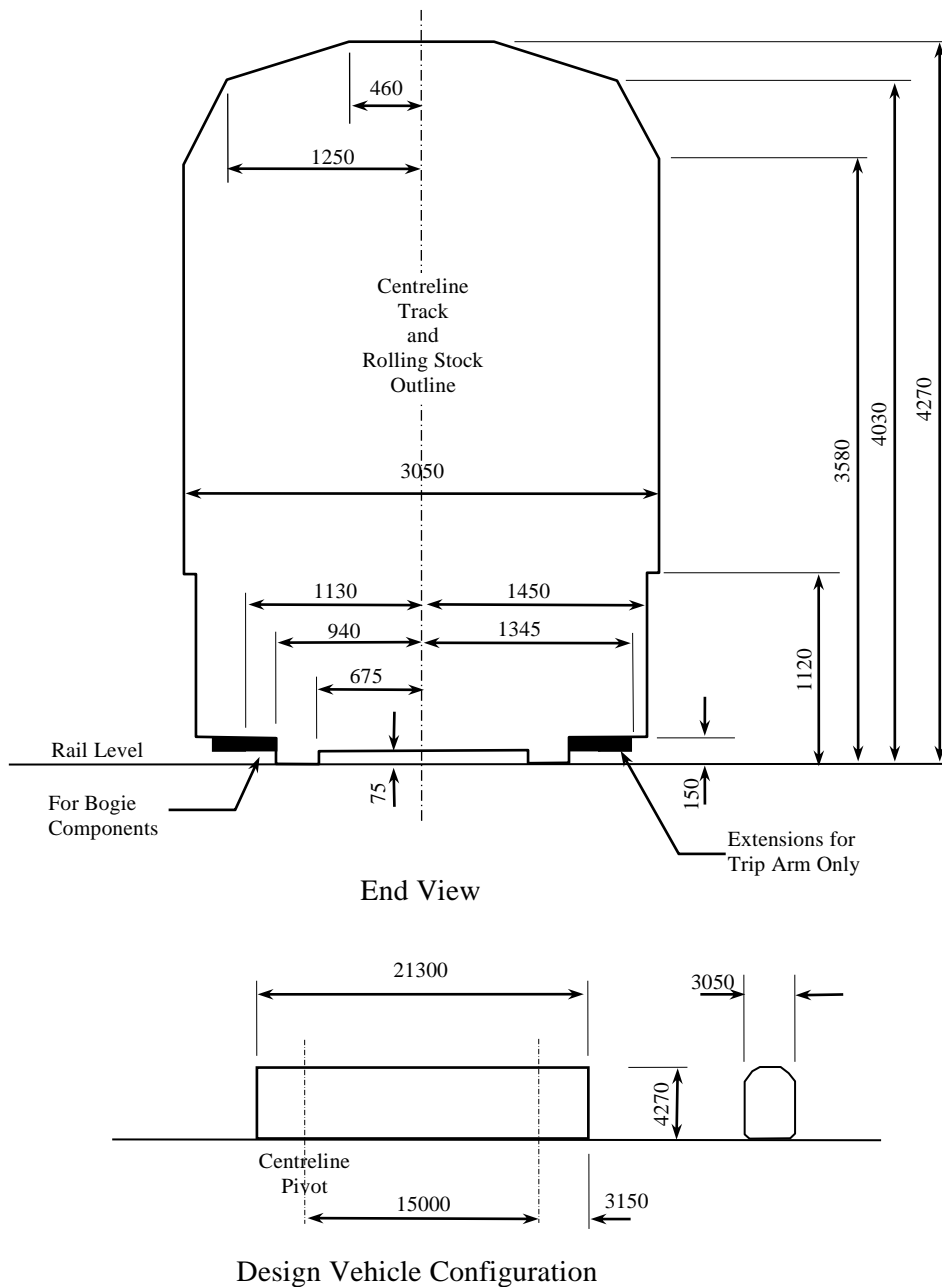

**Notes:**

- [1] The dimensions between bogie pivots and from bogie pivot to end of body should not be increased unless allowance is made by a reduction in width to compensate for increased centre and end throw on a curve of 100 m radius.
- [2] The clearances above rail should be preserved under all conditions of operation, loading and maintenance of a vehicle on level track.
- [3] The area outside the wheels, 80mm above rail and 1130mm from the vehicle centre line shall be occupied by bogie components only.

**Figure A1.5 – Rolling Stock Interstate Outline Plate E1**

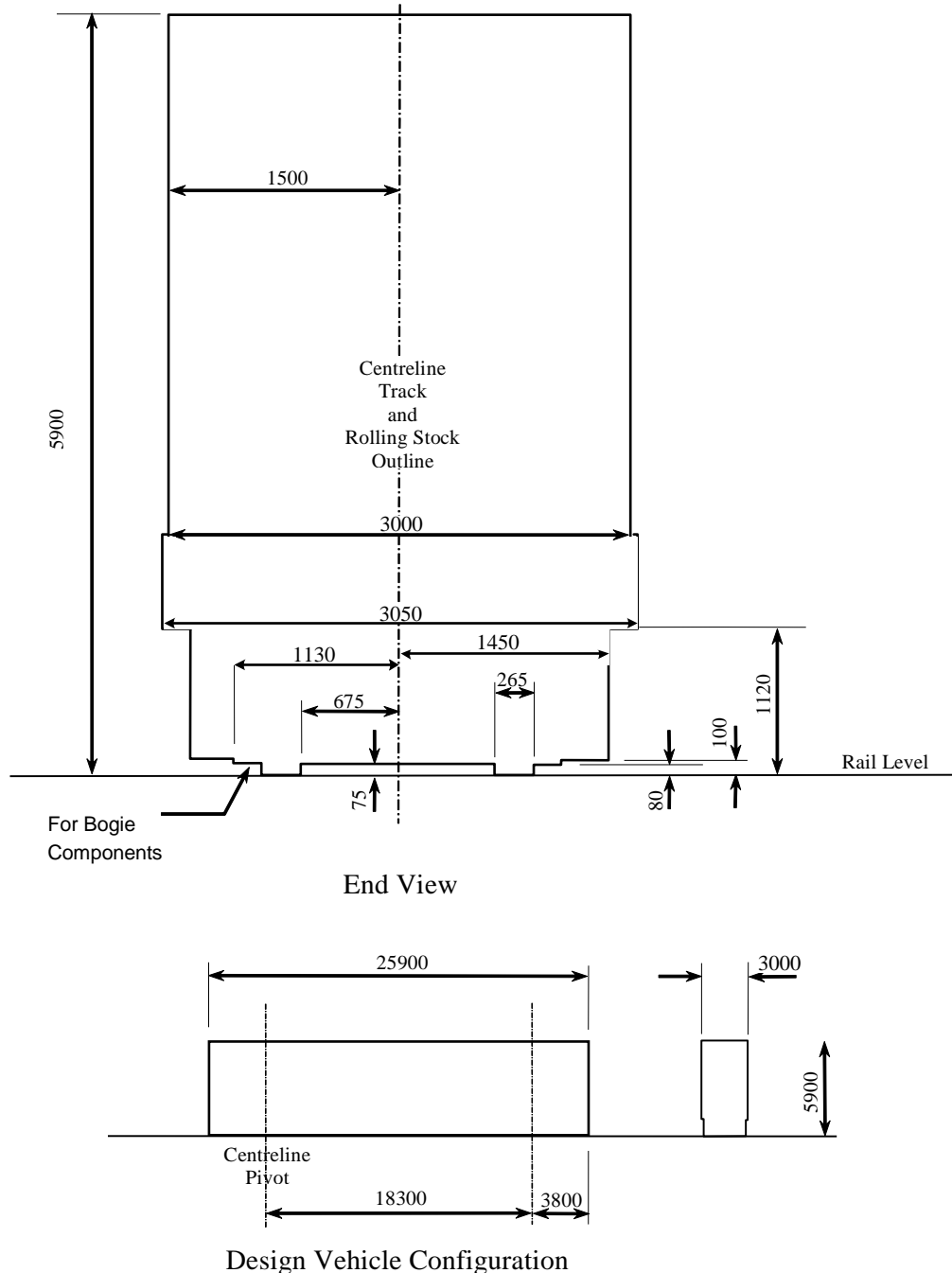

**Notes:**

- [1] *The dimensions between bogie pivots and from bogie pivot to end of body should not be increased unless allowance is made by a reduction in width to compensate for increased centre and end throw on a curve of 100 m radius.*
- [2] *The clearances above rail should be preserved under all conditions of operation, loading and maintenance of a vehicle on level track.*
- [3] *Refer to Diagram A2.7 for notes on operation and loading*



Figure A1.6 – Rolling Stock Interstate Outline Plate F1

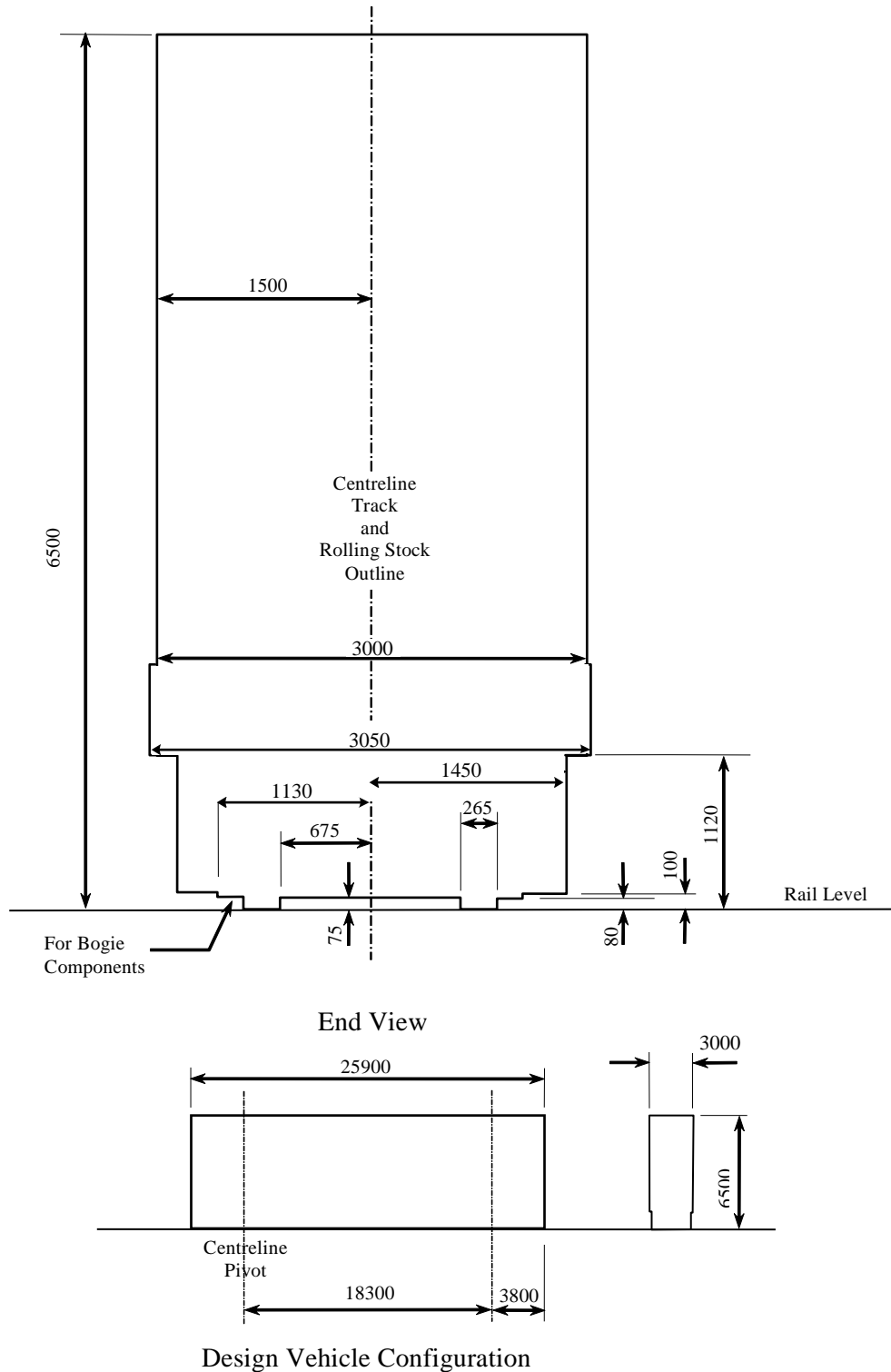

Notes:

- [1] The dimensions between bogie pivots and from bogie pivot to end of body should not be increased unless allowance is made by a reduction in width to compensate for increased centre and end throw on a curve of 100 m radius.
- [2] The clearances above rail should be preserved under all conditions of operation, loading and maintenance of a vehicle on level track.
- [3] Refer to Diagram A2.6 for notes on operation and loading.

Figure A1.7 – Rolling Stock Interstate Outline Plate F2

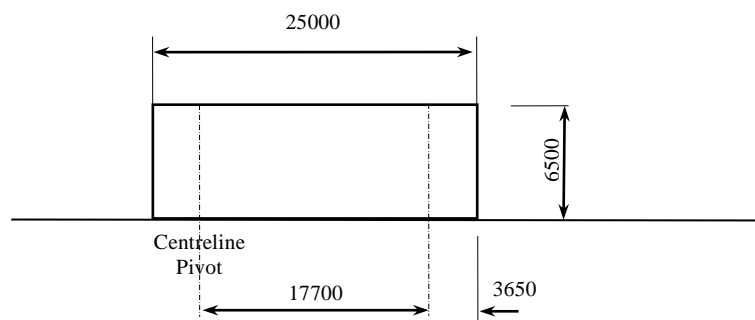
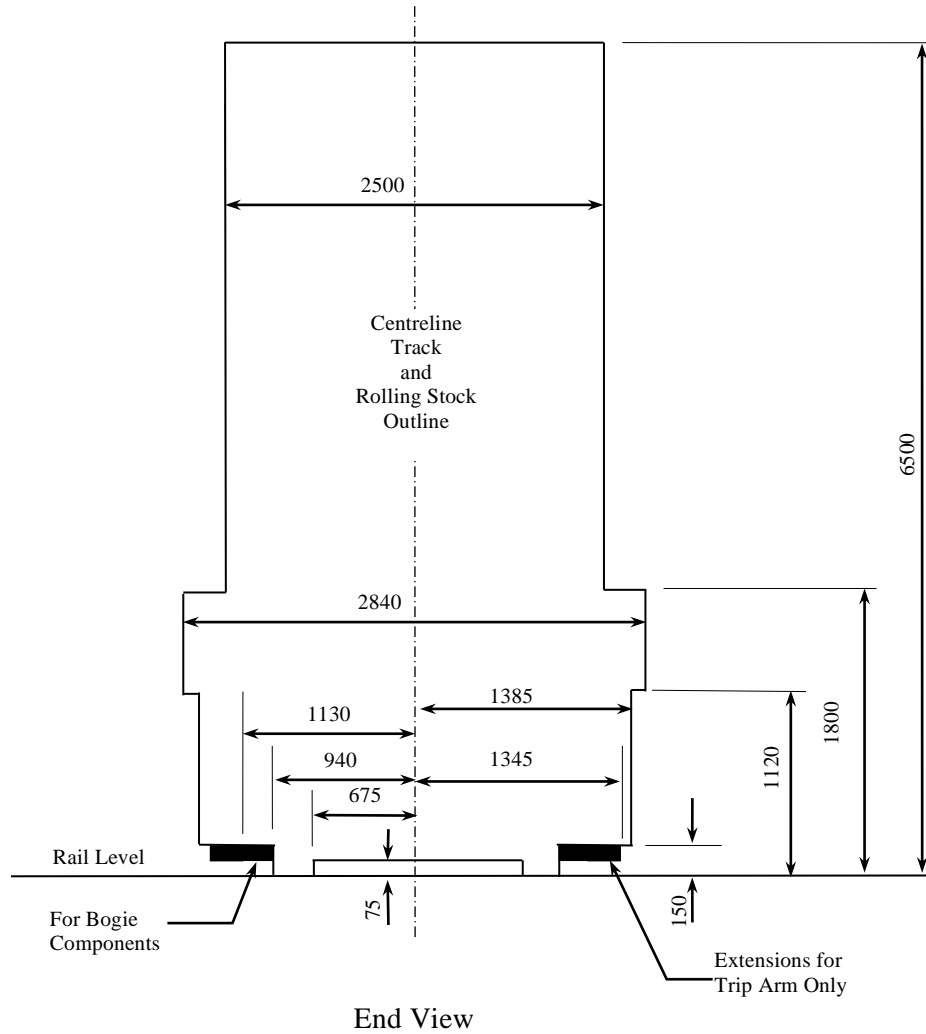

Notes:

- [1] The dimensions between bogie pivots and from bogie pivot to end of body should not be increased unless allowance is made by a reduction in width to compensate for increased centre and end throw on a curve of 100 m radius.
- [2] The clearances above rail should be preserved under all conditions of operation, loading and maintenance of a vehicle on level track.
- [3] Refer to diagram A2.5 for details of areas of operation and loading.

Figure A1.8 – Rolling Stock Interstate Outline Plate H

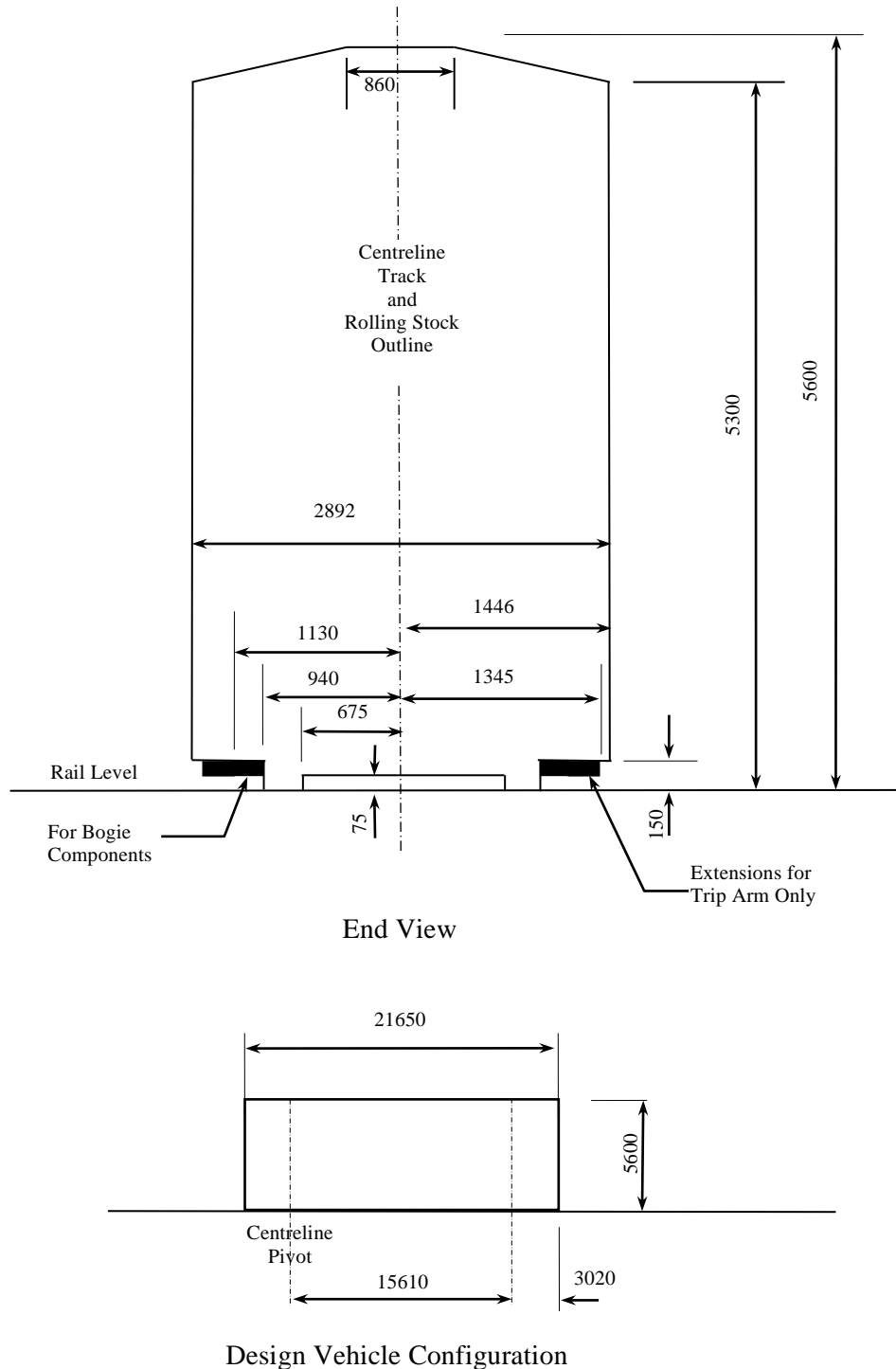

Notes:

- [1] The dimensions between bogie pivots and from bogie pivot to end of body should not be increased unless allowance is made by a reduction in width to compensate for increased centre and end throw on a curve of 100 m radius.
  - [2] At heights above rail to 3580mm the swept path is inside the C profile swept path.
- \* Different end and centre dimension due to doors.

**Figure A1.9 – Rolling Stock Outline Plate CY4150**

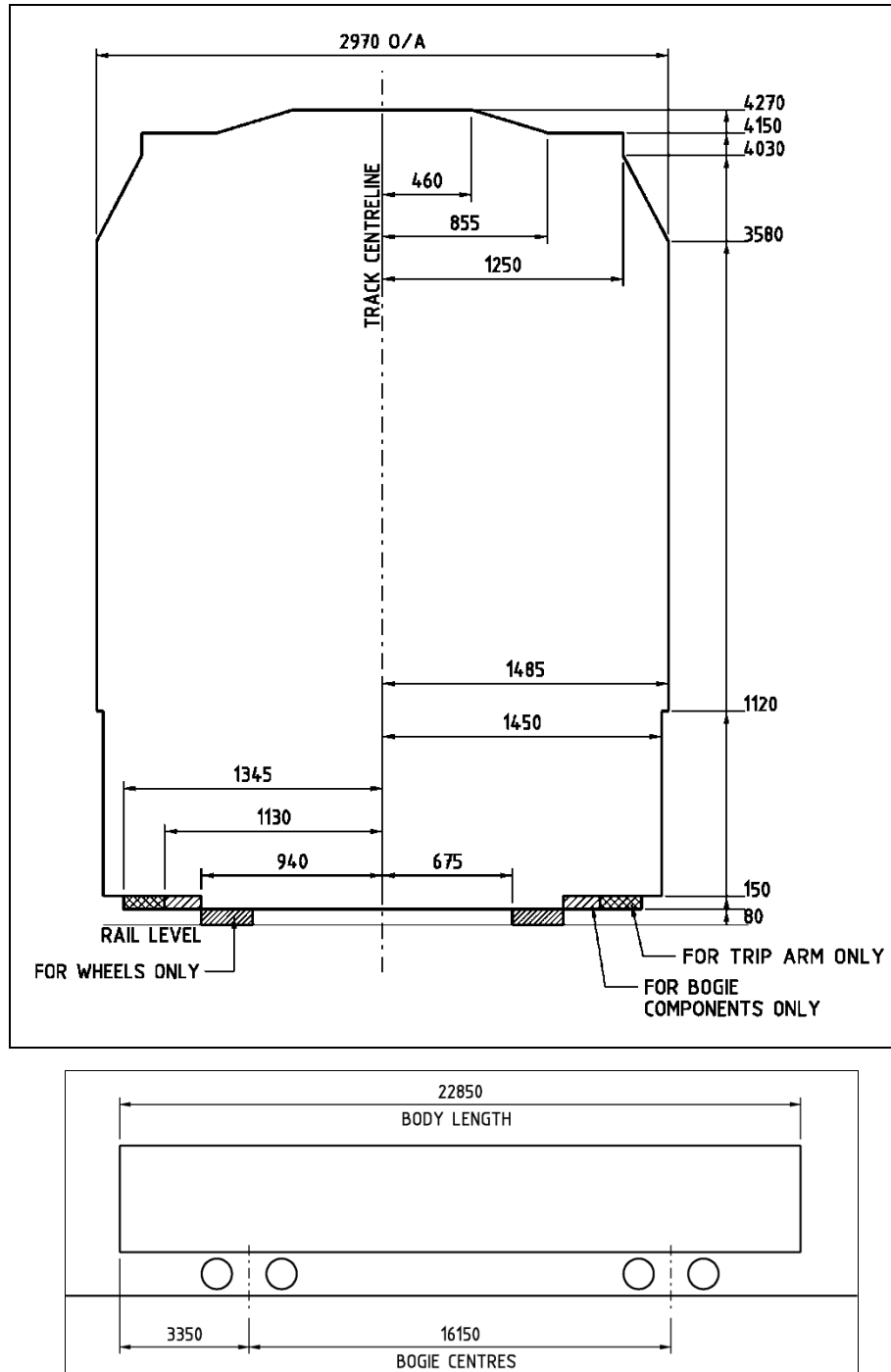

**Notes:**

- [1] The dimensions between bogie pivots and from bogie pivot to end of body should not be increased unless allowance is made by a reduction in width to compensate for increased centre and end throw on a curve of 100 m radius.

**Figure A1.10 – Rolling Stock Outline Plate CZ**

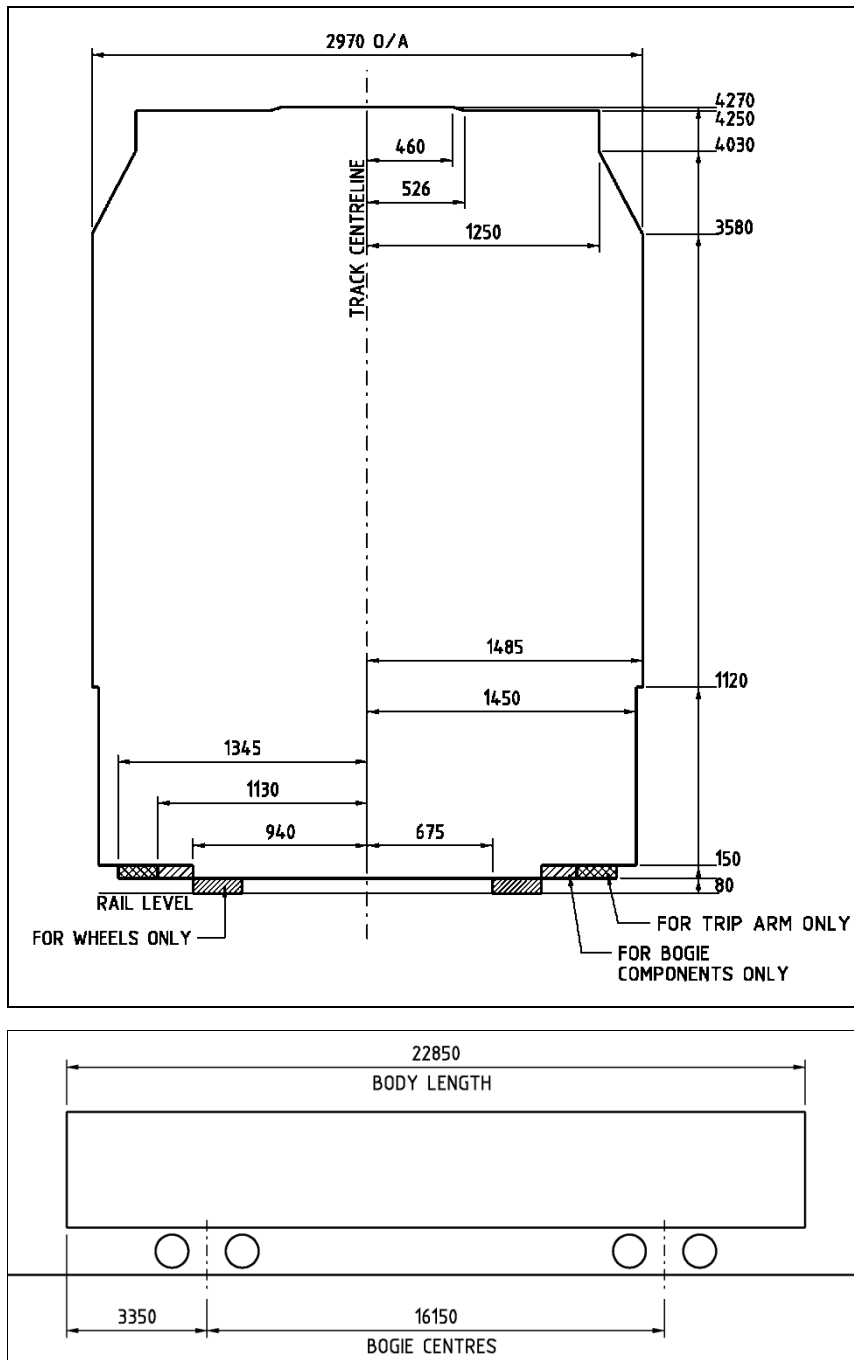

**Notes:**

- [1] The dimensions between bogie pivots and from bogie pivot to end of body should not be increased unless allowance is made by a reduction in width to compensate for increased centre and end throw on a curve of 100 m radius.

**Figure A1.11 – Rolling Stock Outline Plate Narrow Non-Electric (NNE)**

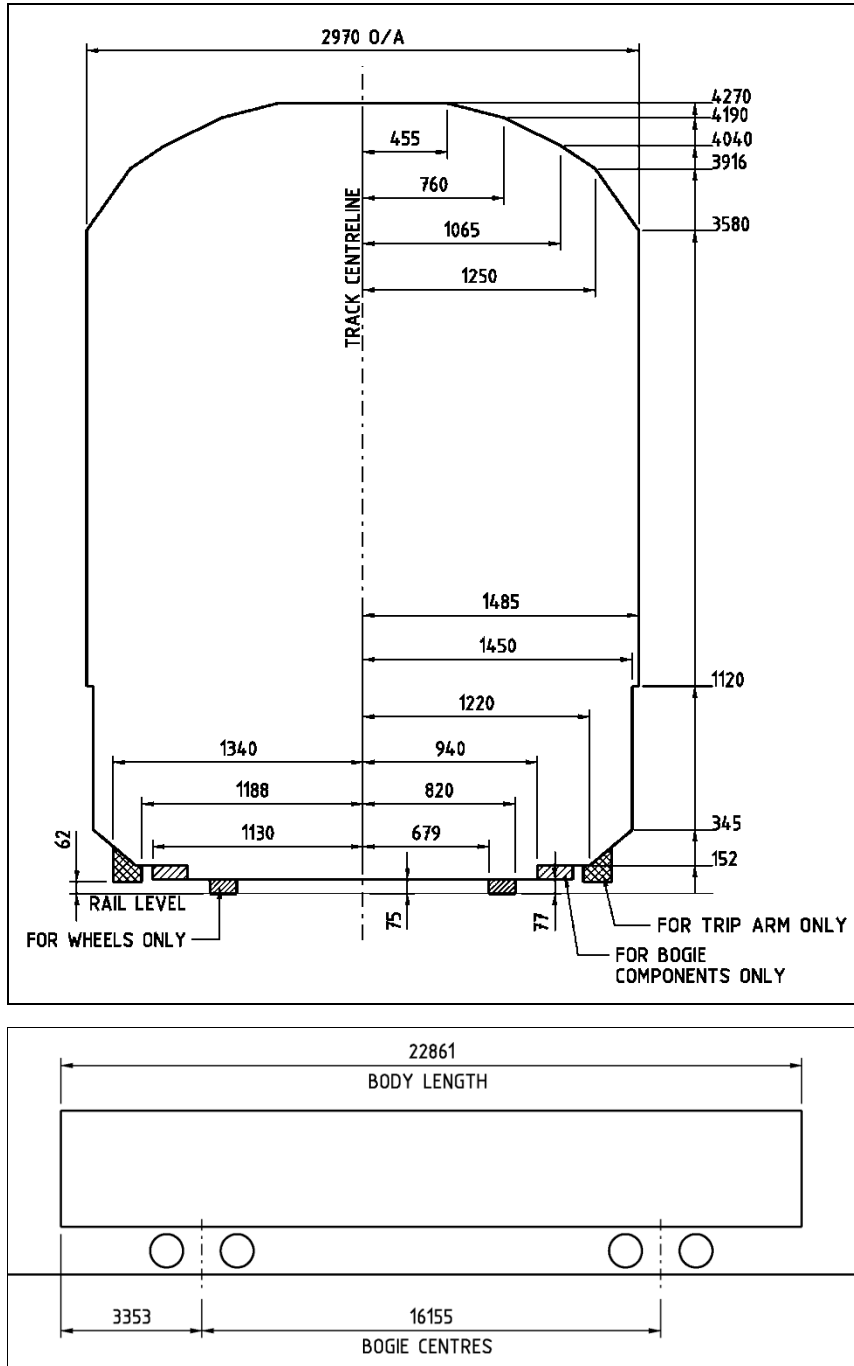

**Notes:**

- [1] *The dimensions between bogie pivots and from bogie pivot to end of body should not be increased unless allowance is made by a reduction in width to compensate for increased centre and end throw on a curve of 100 m radius.*

**Figure A1.12 – Rolling Stock Outline Plate NSW Narrow Container (NC)**

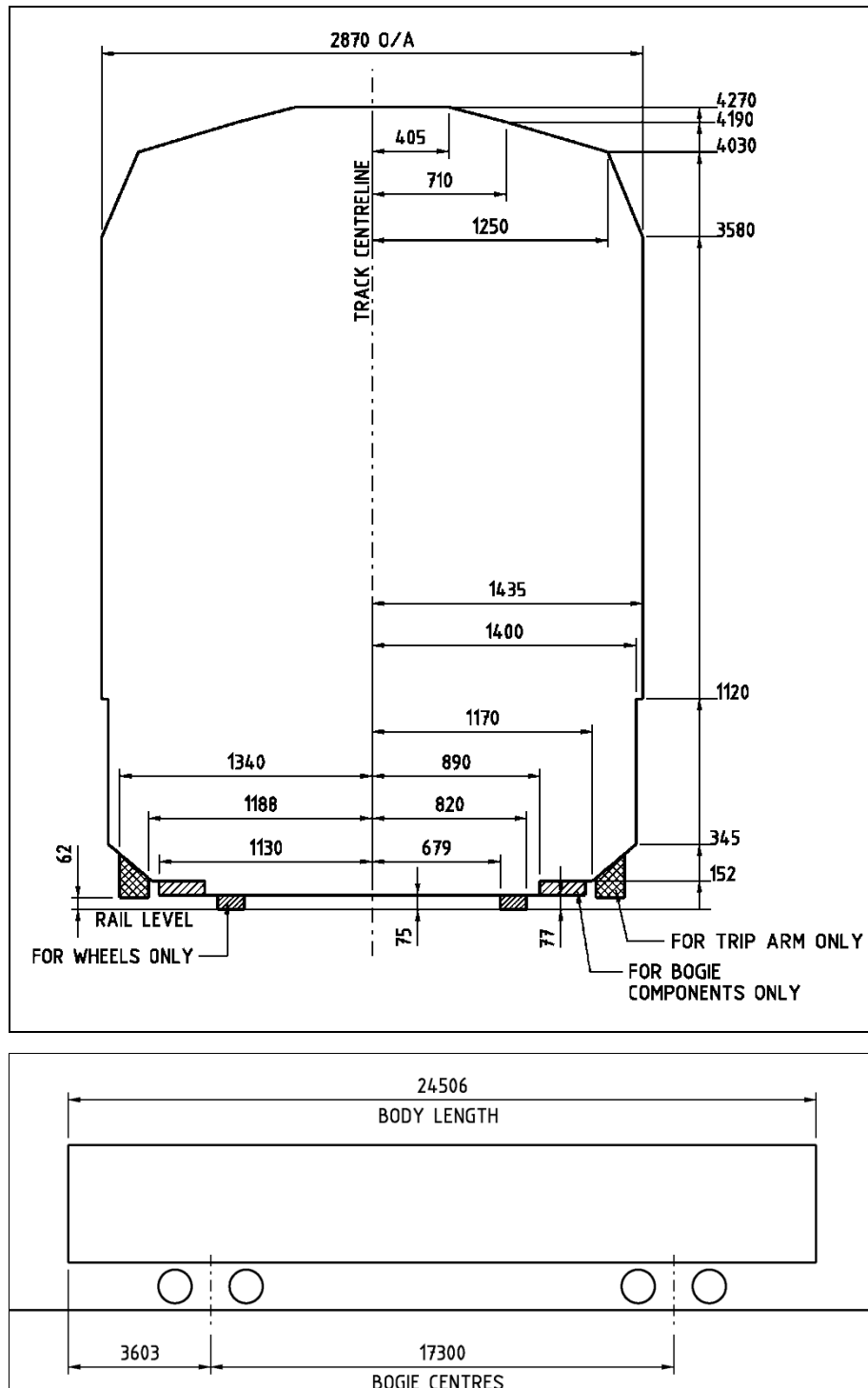

**Notes:**

- [1] The dimensions between bogie pivots and from bogie pivot to end of body should not be increased unless allowance is made by a reduction in width to compensate for increased centre and end throw on a curve of 100 m radius.





**Figure A1.14 – Rolling Stock Outline Plate NSW Inter System (IS)**

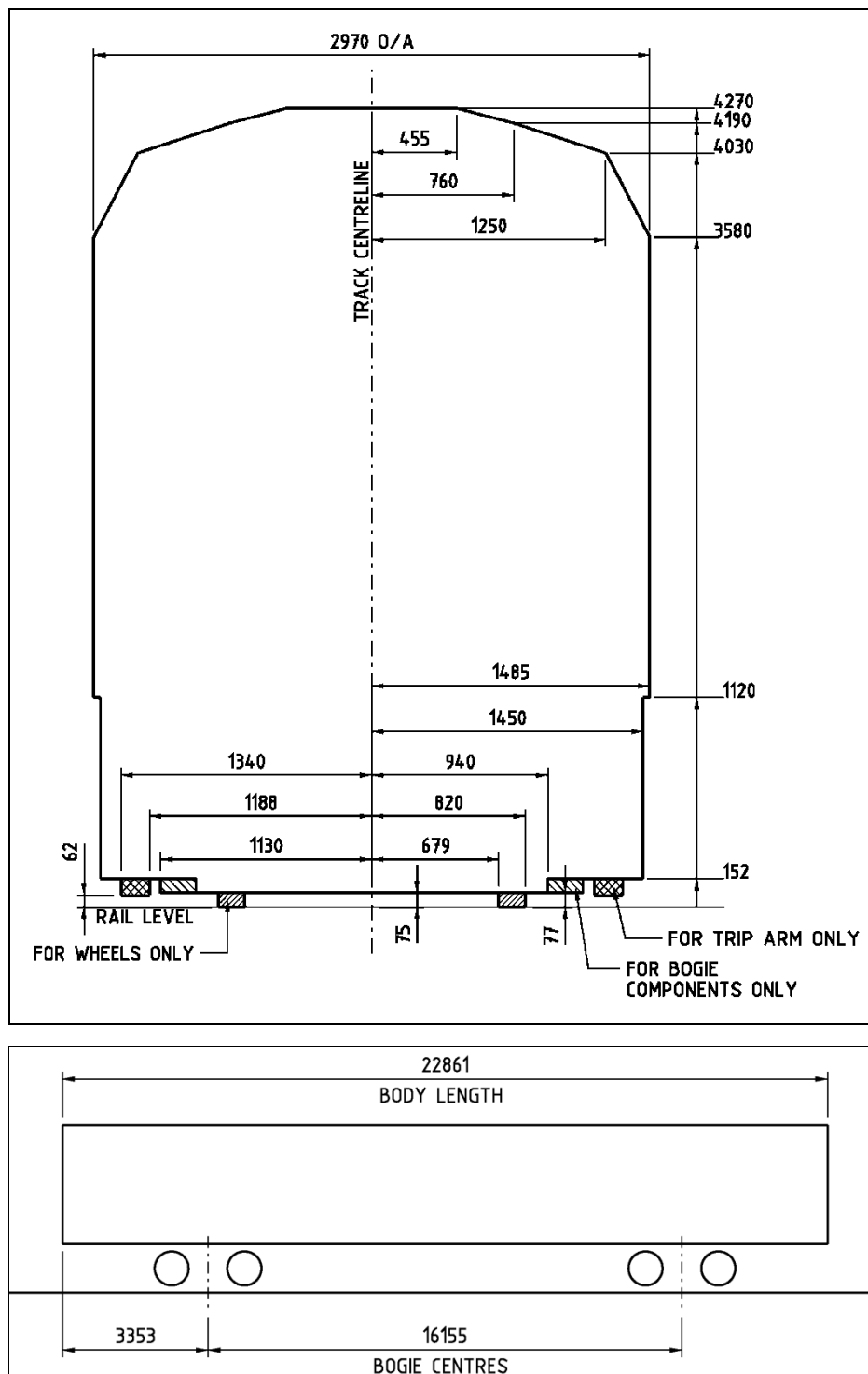

**Notes:**

- [1] The dimensions between bogie pivots and from bogie pivot to end of body should not be increased unless allowance is made by a reduction in width to compensate for increased centre and end throw on a curve of 100 m radius.

**Figure A1.15 – Rolling Stock Outline Plate NSW Narrow Hopper (NH)**

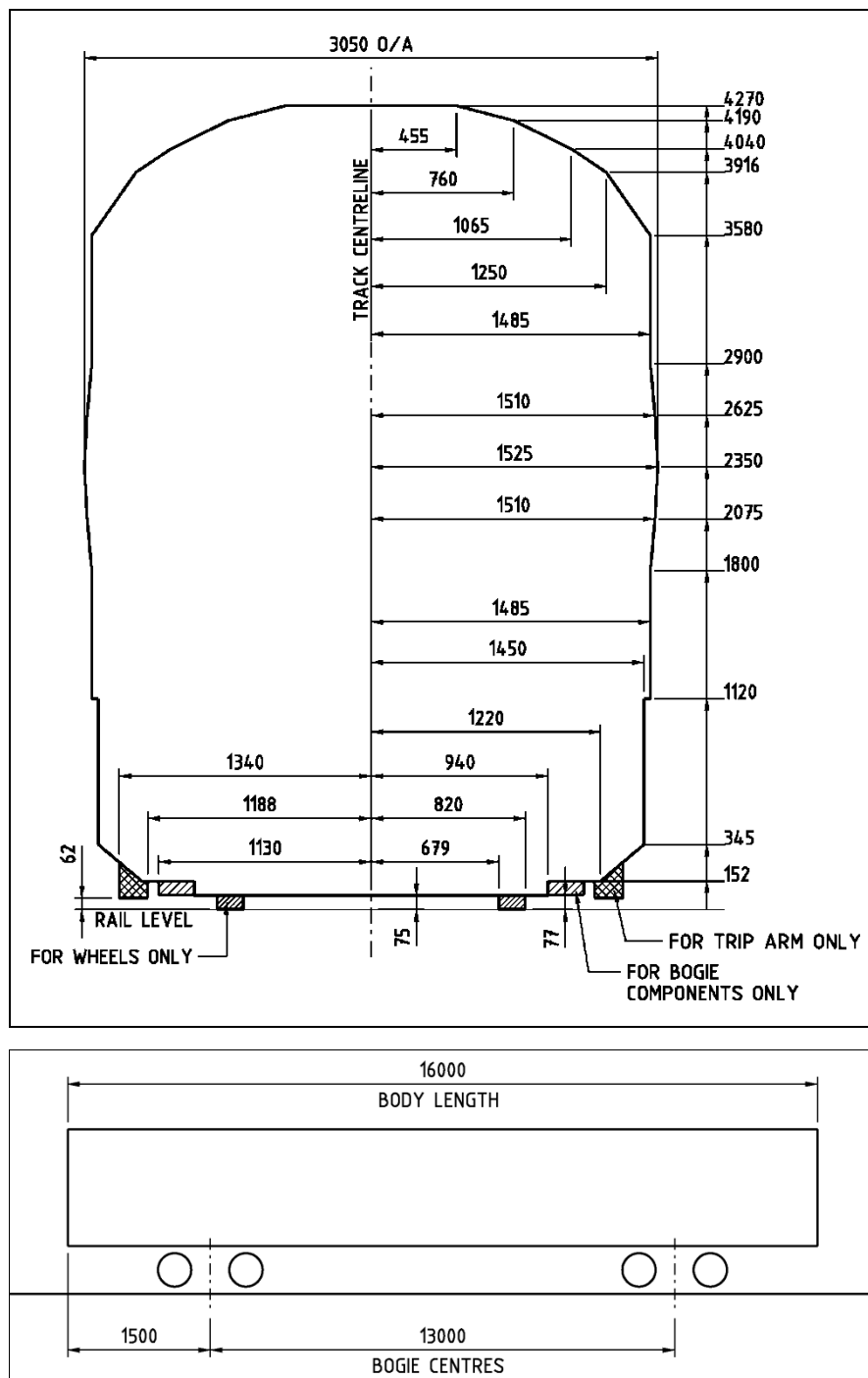

**Notes:**

- [1] The dimensions between bogie pivots and from bogie pivot to end of body should not be increased unless allowance is made by a reduction in width to compensate for increased centre and end throw on a curve of 100 m radius.

**Figure A1.16 – Rolling Stock Outline Plate NSW Double Stacking (DS)**

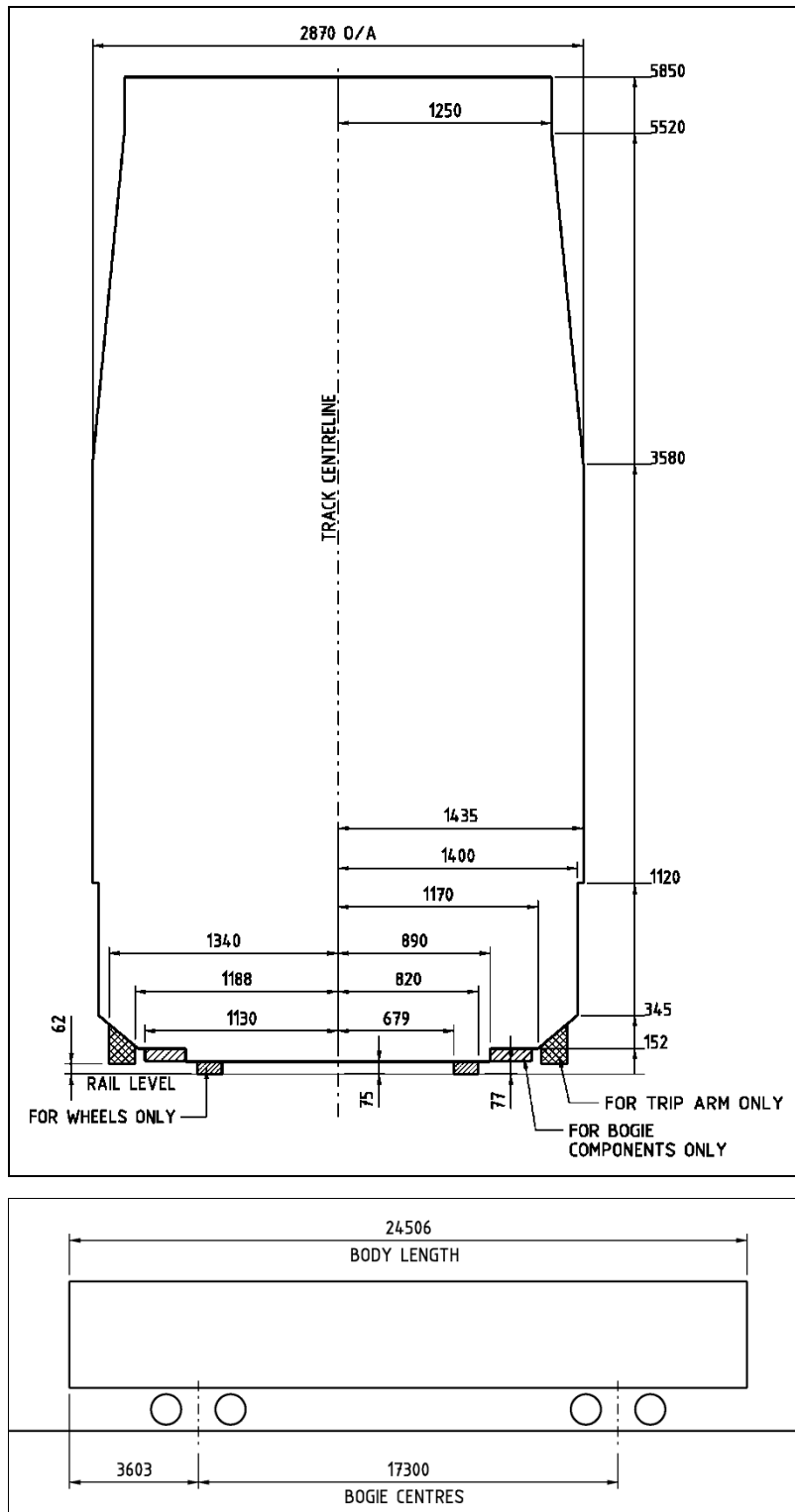

**Notes:**

- [1] The dimensions between bogie pivots and from bogie pivot to end of body should not be increased unless allowance is made by a reduction in width to compensate for increased centre and end throw on a curve of 100 m radius.

**Figure A2.1 Maximum Loading Dimensions for Loose Loads for Unrestricted Operation Throughout the ARTC Network**

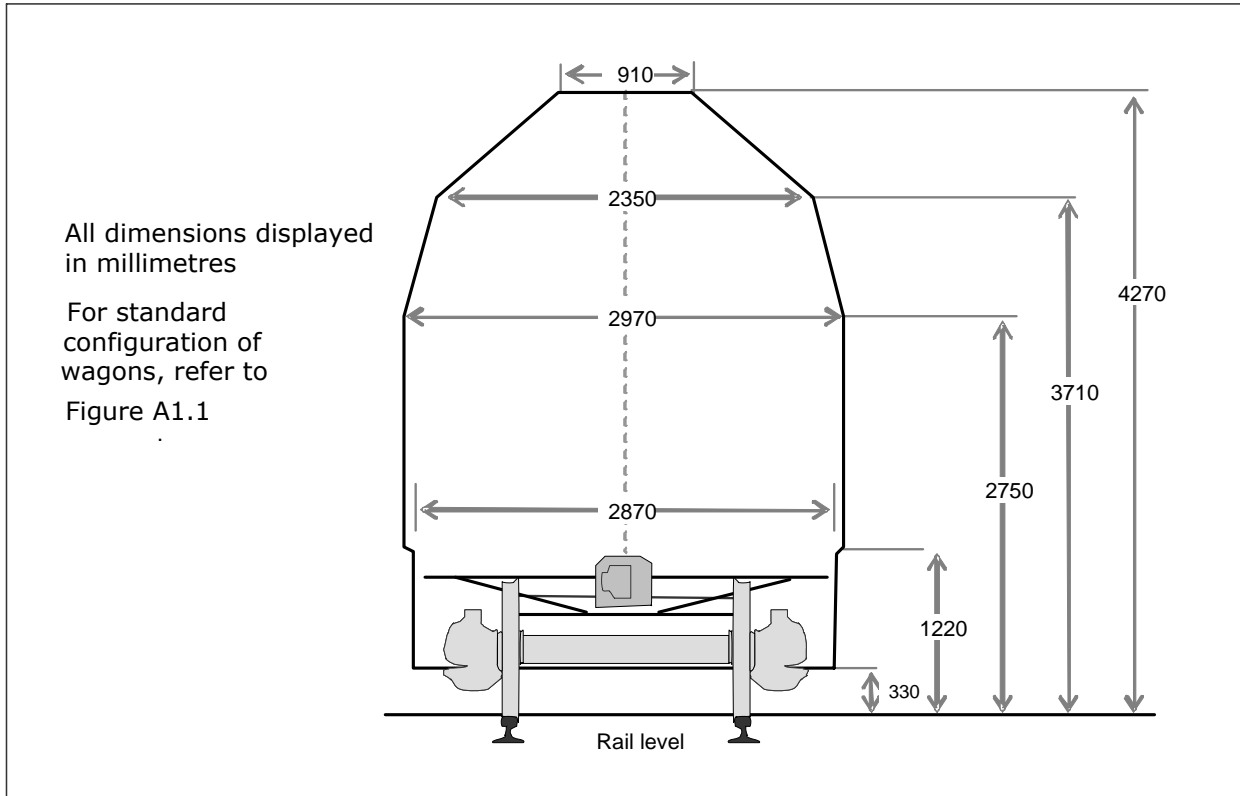

Notes for Figure A2.1:

Figure A2.1 applies to the loading and security of:

- moveable loads (loose loads) that are not enclosed in a solid container
- loads that can become displaced
- loads not rigidly attached to the vehicle subject to inaccurate placing on wagon
- loads secured by means of lashing devices
- any load not in a fully enclosed container.

This diagram depicts the dimensional load limit for flat, open and transflat container wagons, including flat container bases.

Any loading exceeding the dimensions shown are classified as out of gauge and may only be conveyed under special conditions as determined by ARTC.

Loading outline includes lashings, chains and securing equipment.

The above diagram is based on those dimensions as shown in Figure A1.1 and A1.11.

Loading outline includes lashings, chains and securing equipment.

Based on rolling stock dimensions of:

- maximum 22860 mm (length)
- maximum 2970 mm (width)

- with 16155 mm bogie centres.

**Figure A2.2 Maximum Standard Loading Dimension for Motor Vehicles on Motorail Wagons for Unrestricted Operation Throughout the ARTC Network**

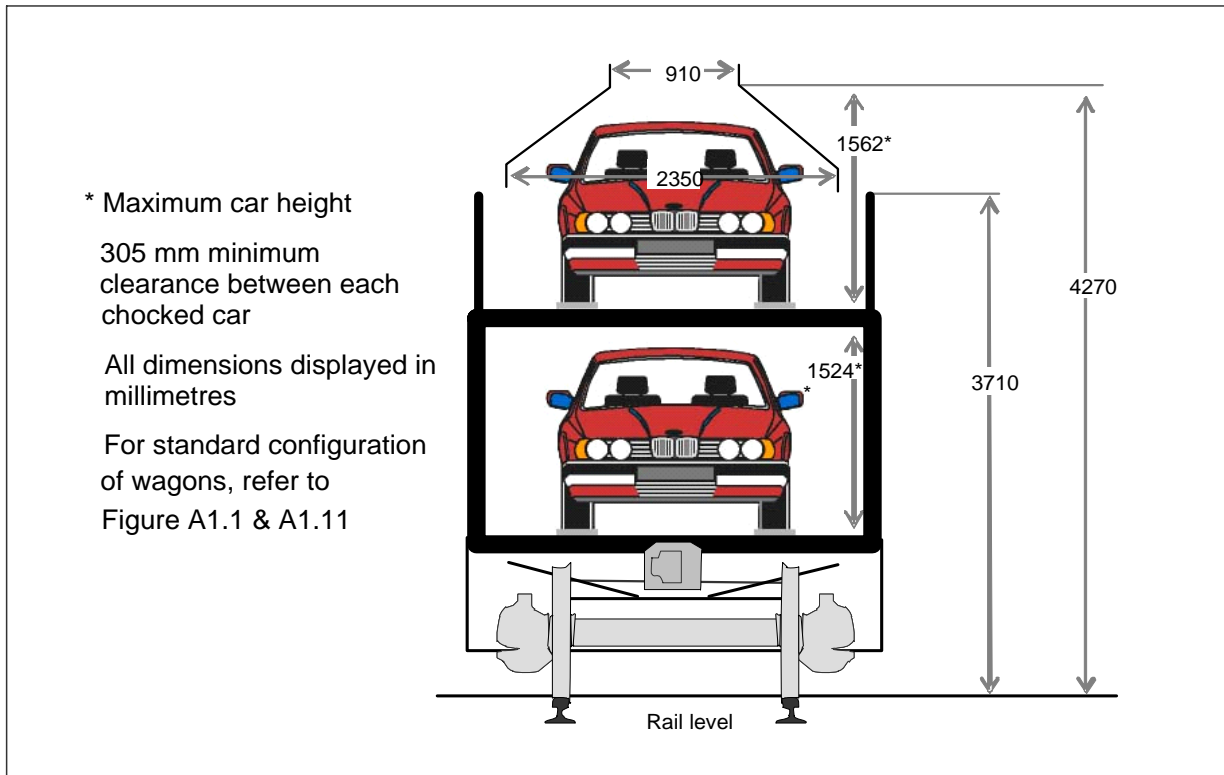

Notes for Figure A2.2:

- Car aerials shall be in the down position
- Vehicles are permitted to carry roof-racks provided they are properly secured to the vehicle and the height (including the roof-rack) does not exceed the listed dimensions
- The maximum wheel track width is 1830 mm measured from the extreme outside edge of the tyres.
- Operators shall have procedures in place to manage centre of gravity when vehicles are only loaded on the top deck.

**Figure A2.3 - Maximum Container Loading for Unrestricted Operation Throughout the ARTC Network**

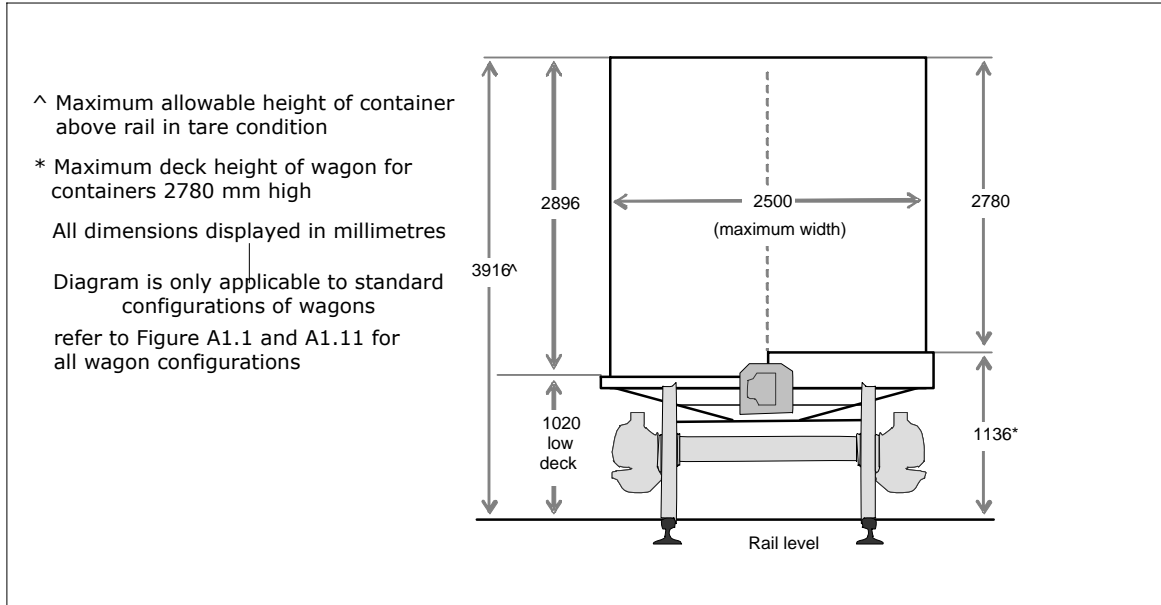

**Figure A2.4 - Maximum Container Loading to meet Plates C, D, NC, NS, and IS**

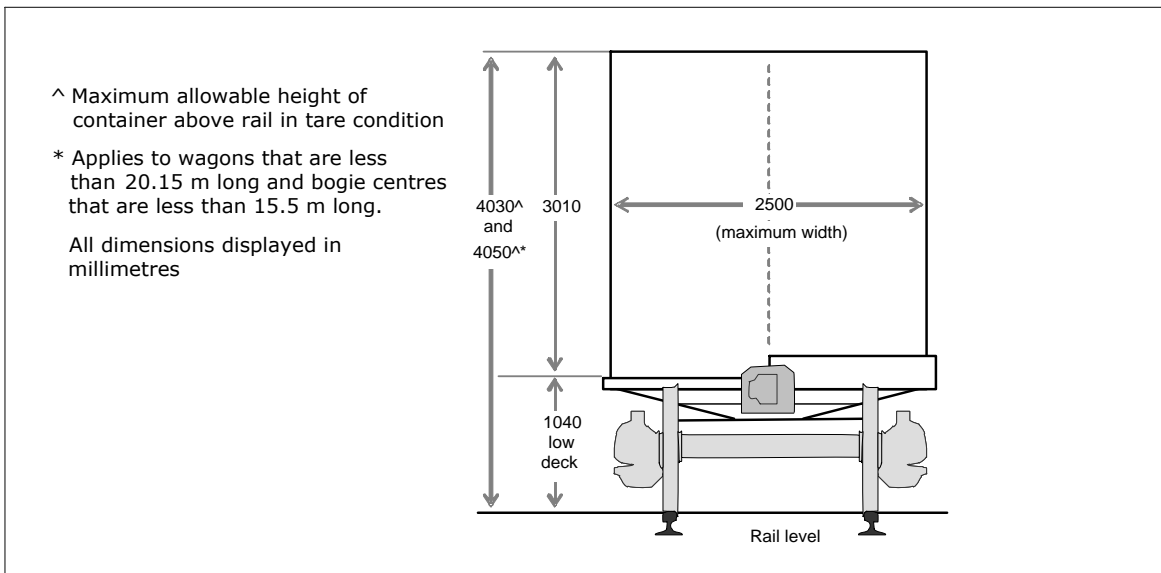

Notes

for Figure A2.4:

For standard configurations of the applicable wagons refer diagrams: A1.3, A1.4, A1.12, A1.13 and A1.14.

Figure A2.5 - Double Stacking of Containers to meet Plate F2

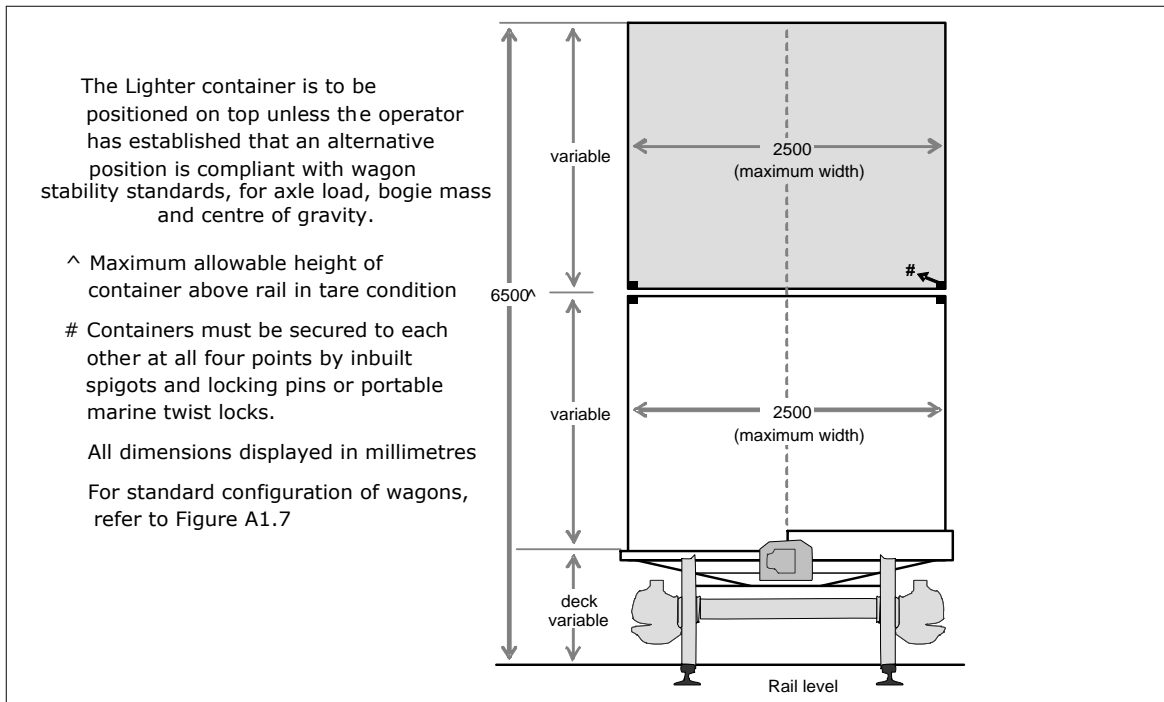

Figure

e A2.5.1 Areas of operation for containers loaded to meet Plate F2

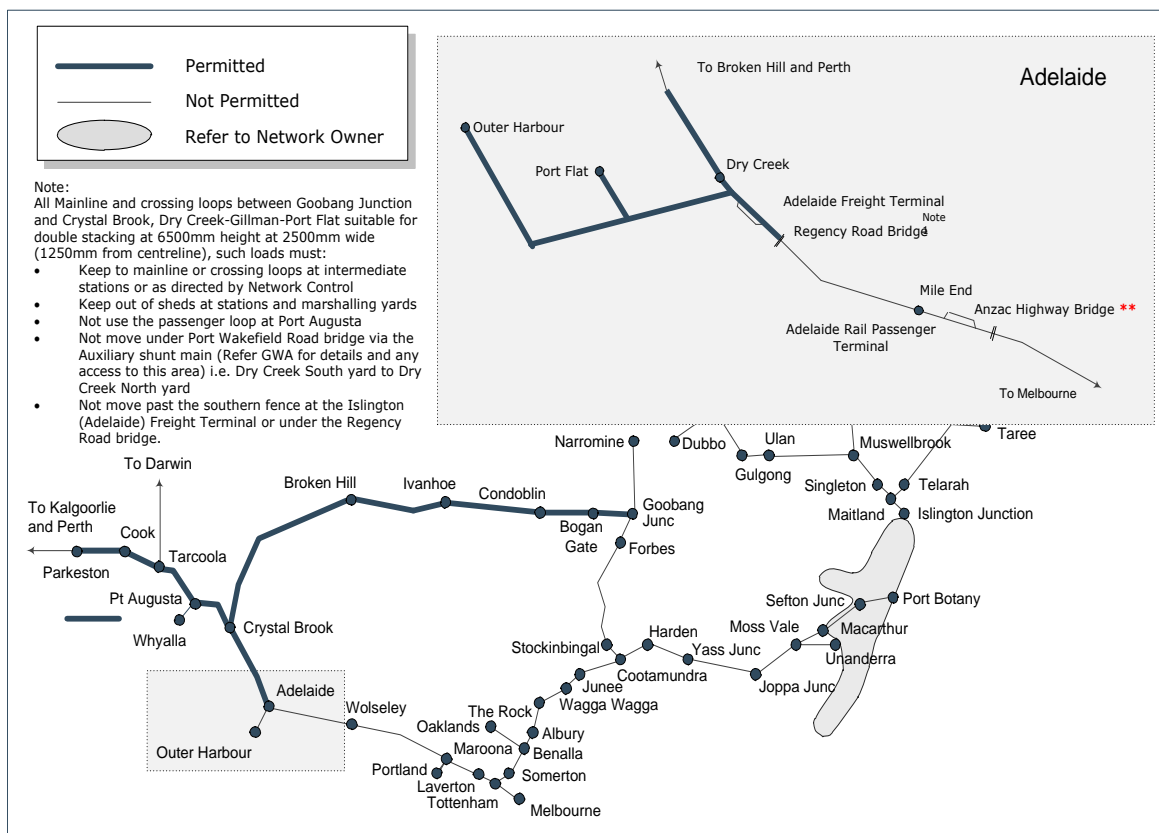

Opera

tion of double stacked wagons and wagons meeting the high cube outline to operate through Broken Hill as follows:

- When passing the Broken Hill Passenger Platform, reduce speed to 25km/hr
- Alternately at the availability and discretion of the Network Controller, traffic can be diverted



through either the Broken Hill “South Through Road” or Goods Loop at published speeds.

**Figure A2.6 - Double Stacking of Containers to Meet Plate F1**

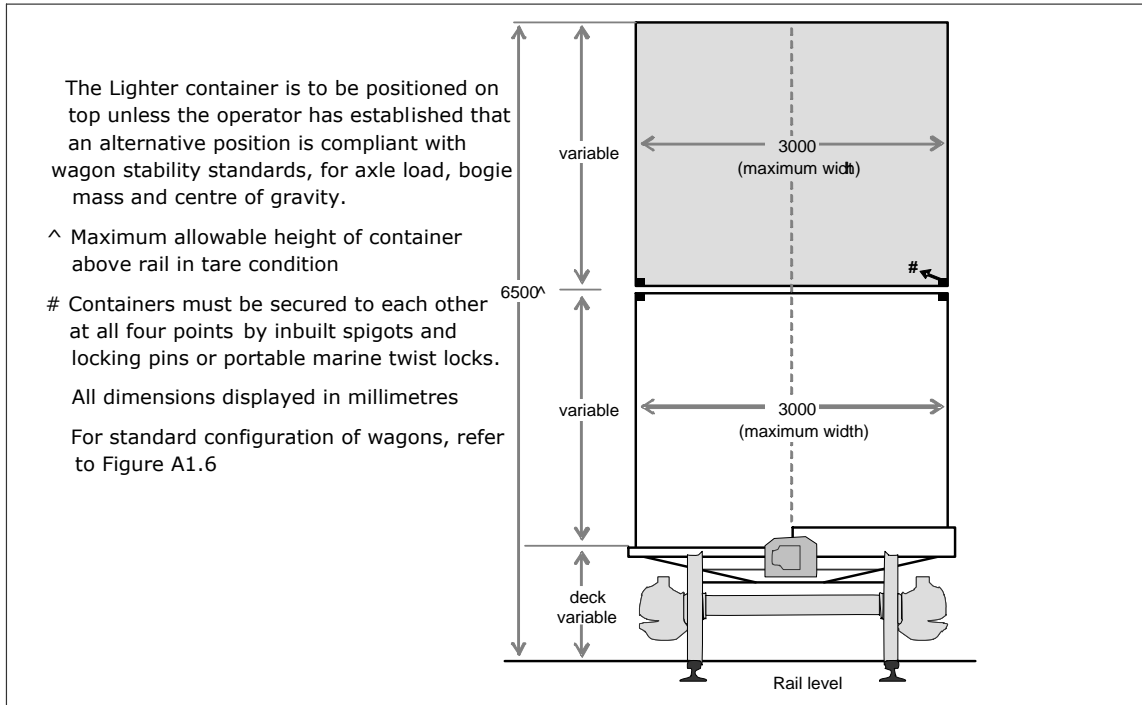

**Figure A2.6.1 Areas of operation for containers loaded to meet Plate F1**

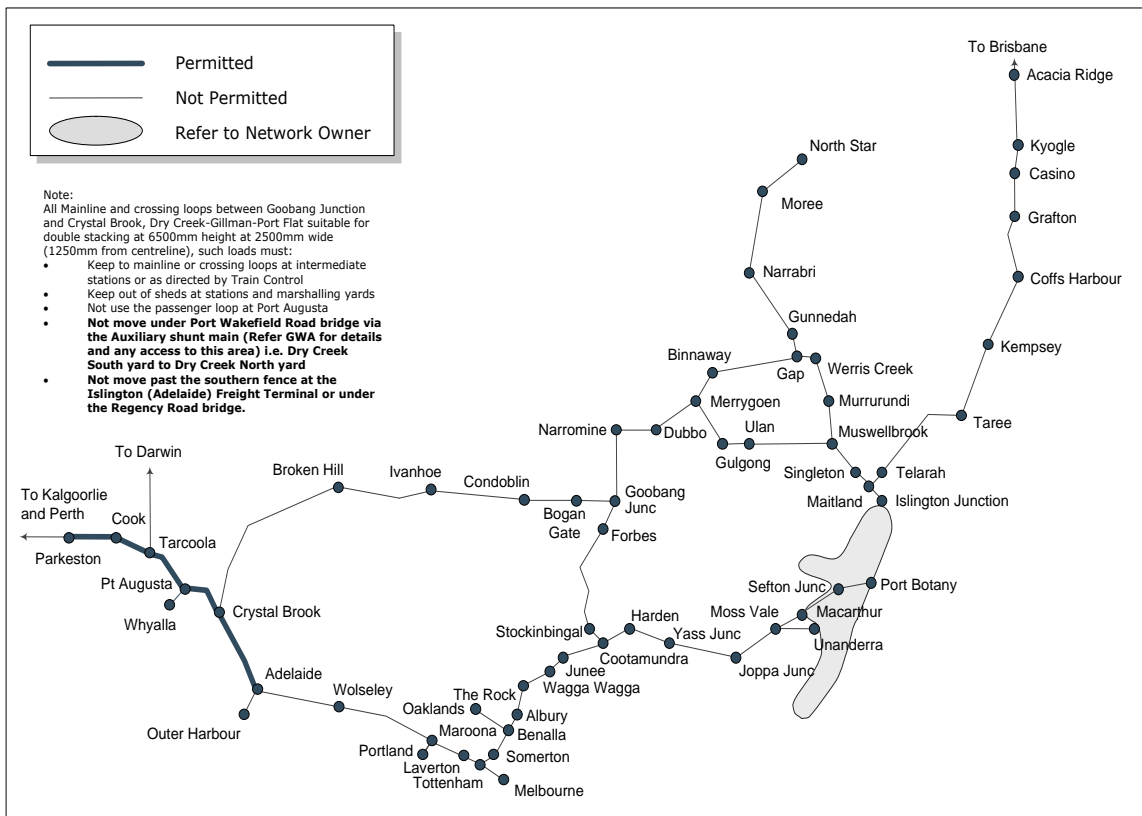

**Figure A2.7 - Double Stacking of Containers to Meet Plate E1**

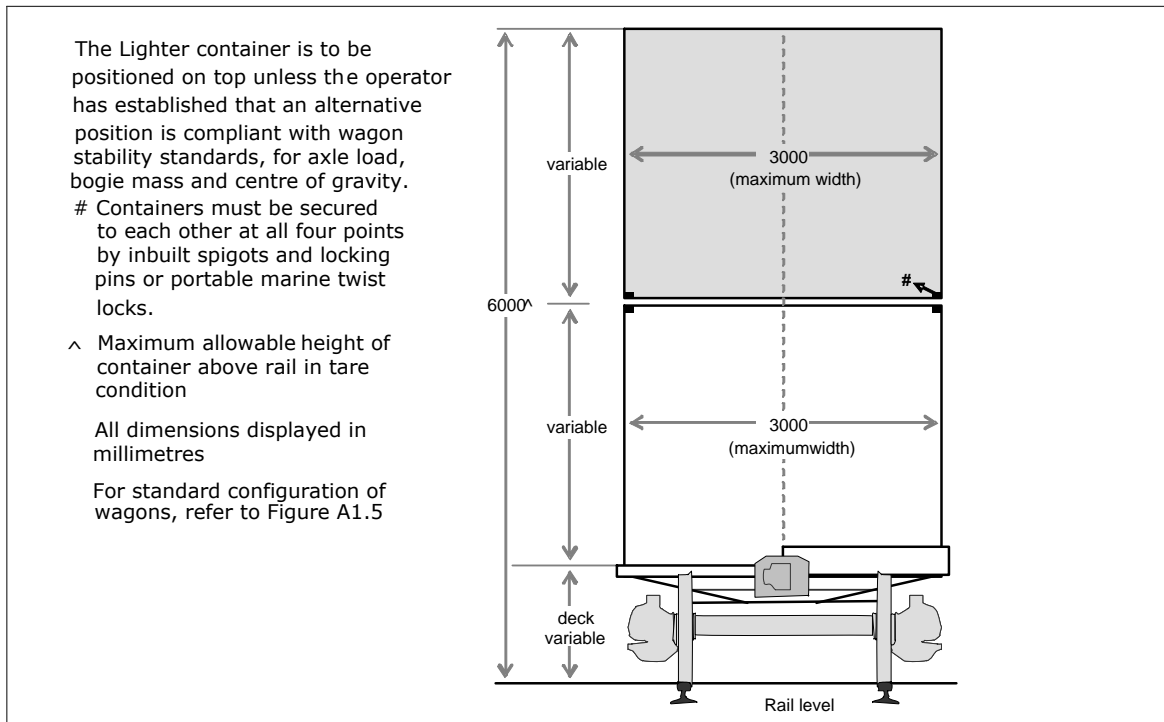

**Figure A2.8 - 4220 mm High Maximum Container Loading For Specified Corridors in NSW**

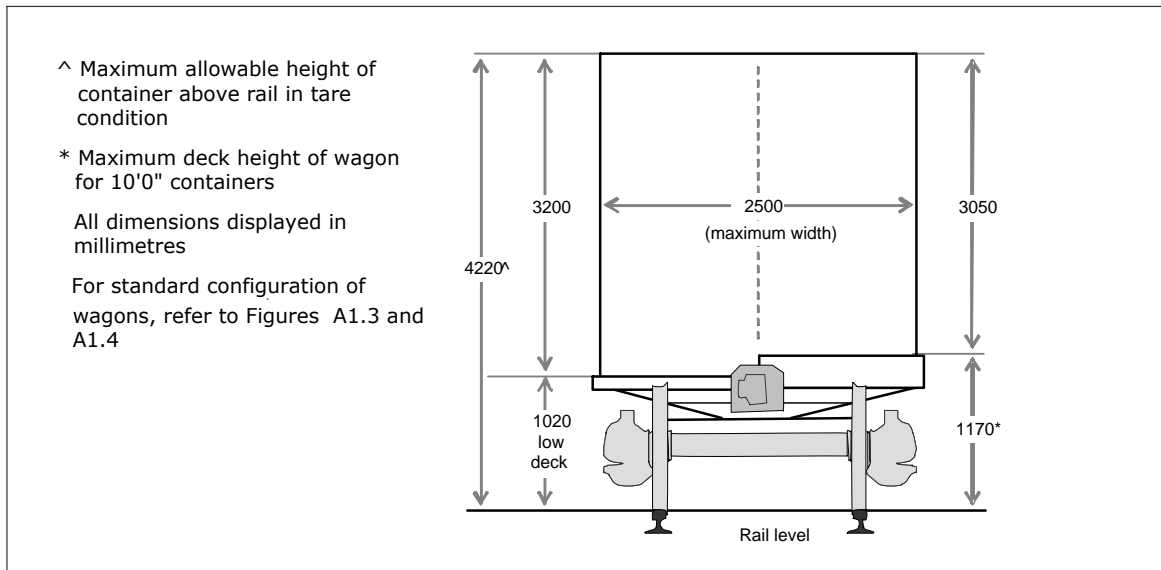

**Figure A2.8.1 – Diagram for Area of Operation for Figure A2.8**

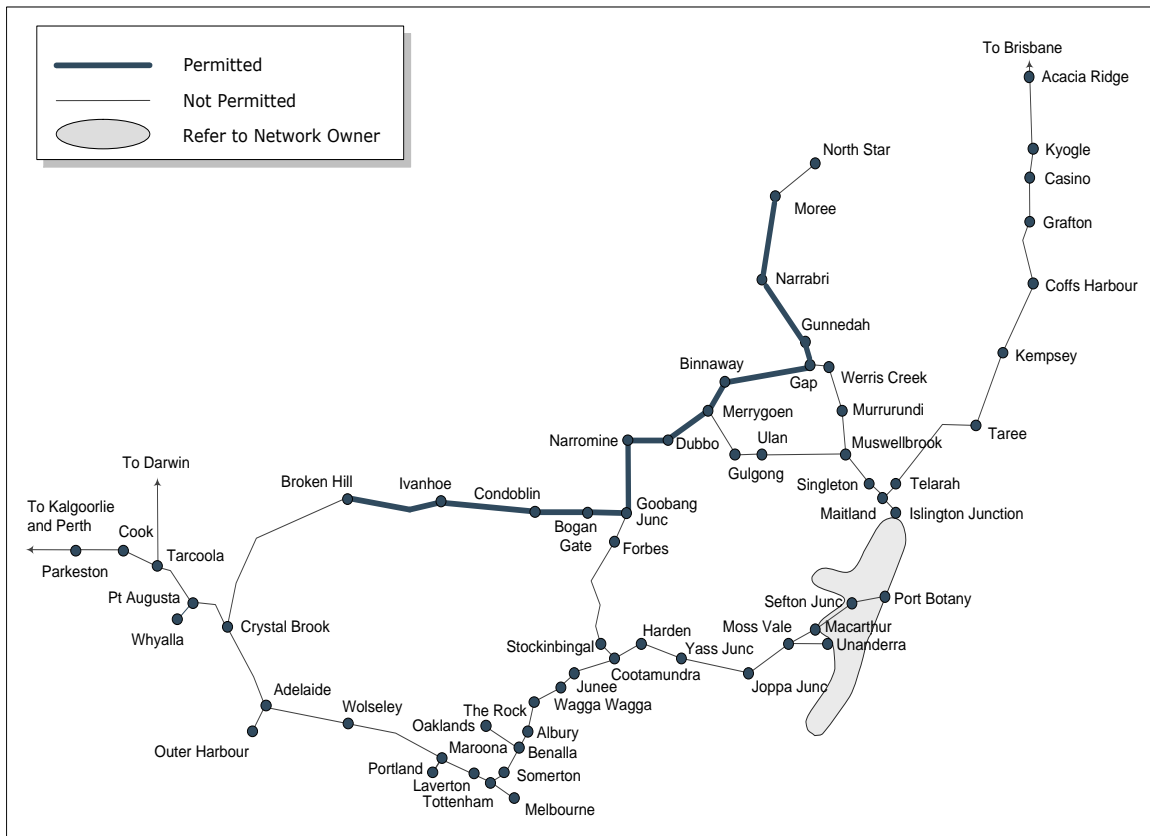

**Figure A2.9 – Maximum Container Loading from Melbourne to Albury**

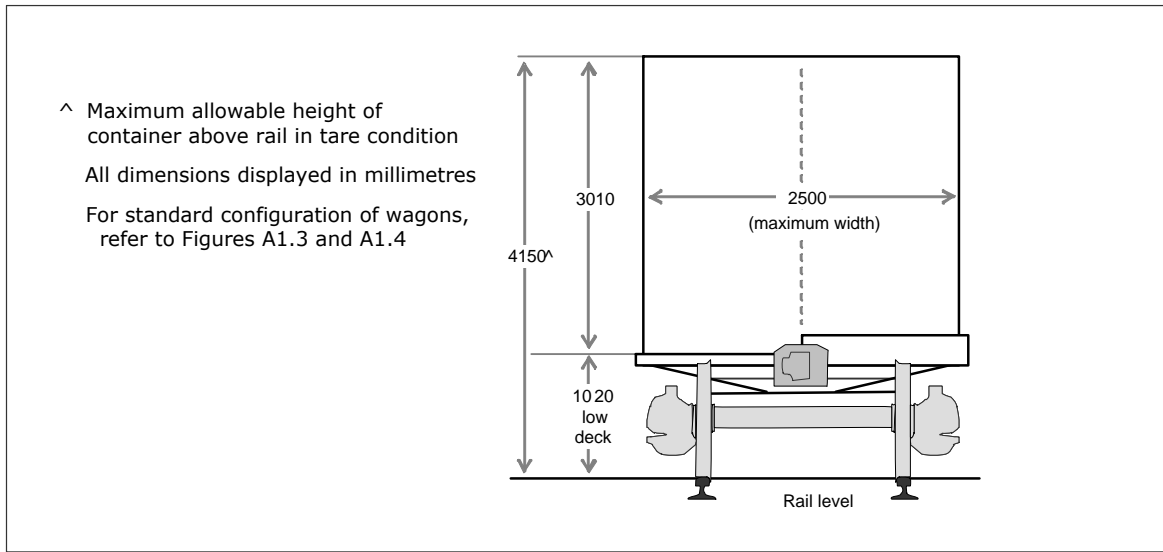

**Figure A2.9.1 – Diagram for Area of Operation for Figure A2.9**

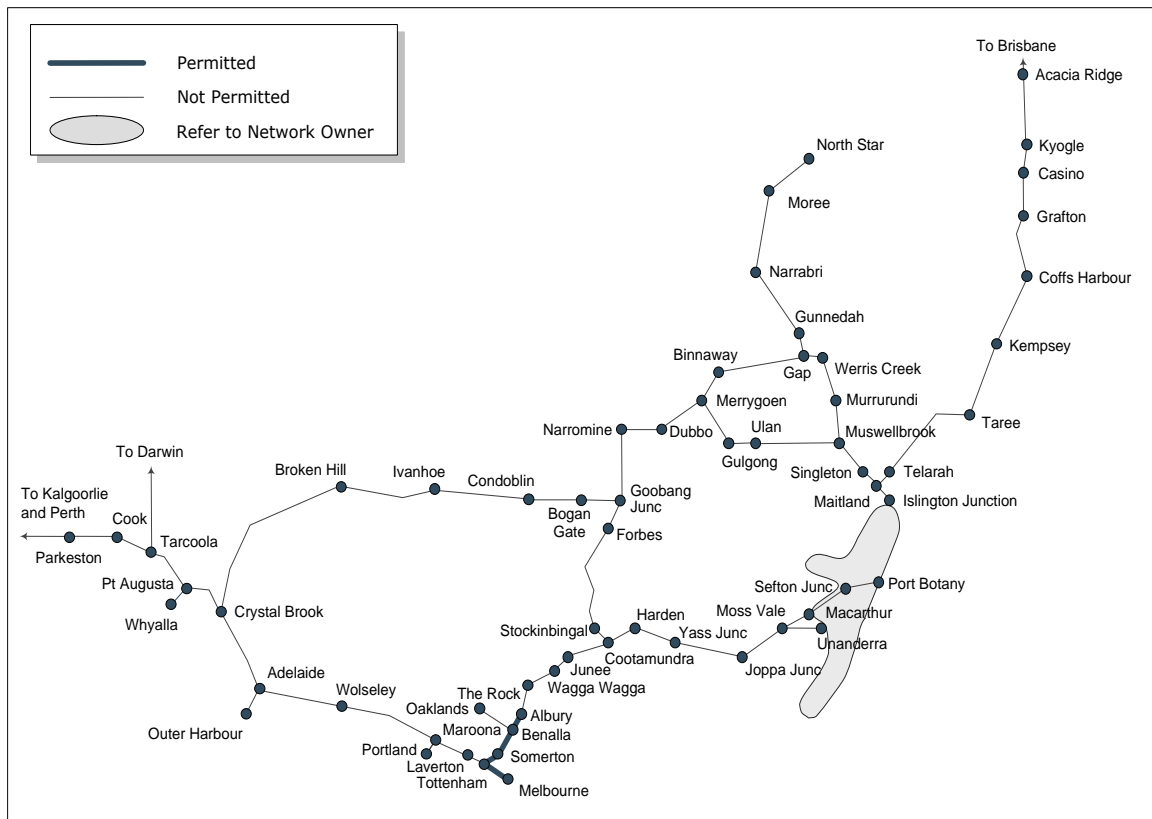

**Figure A2.10 – Maximum Container Loading from Adelaide to Melbourne**

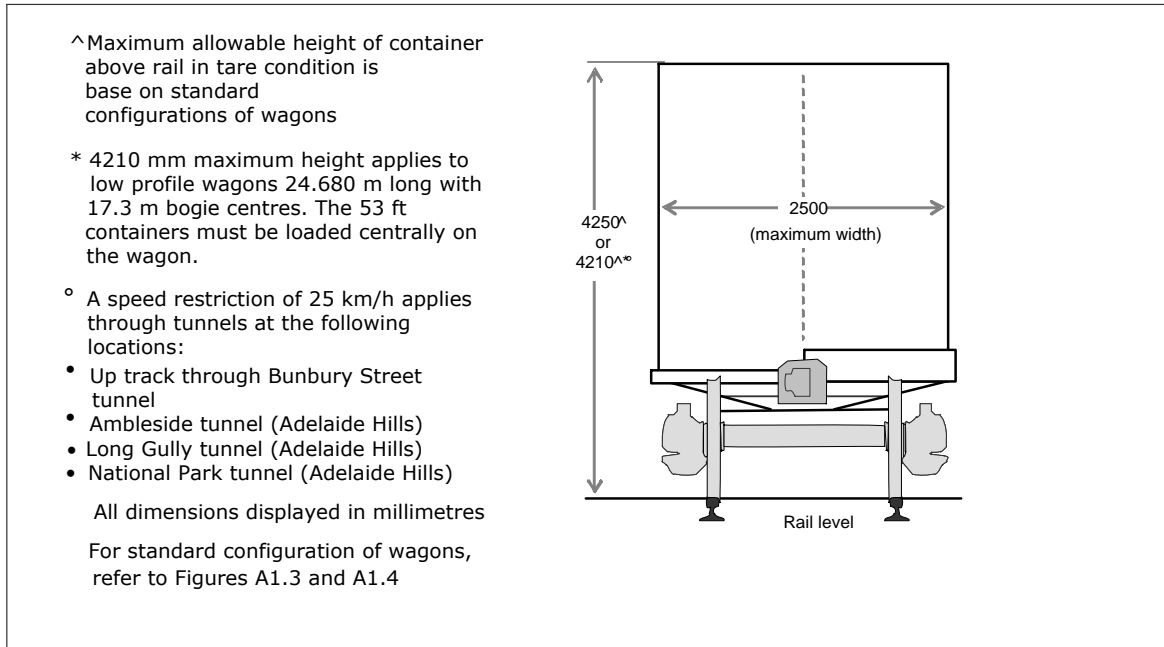

**Figure A2.10.1 – Diagram for Area of Operation for Figure A2.10**

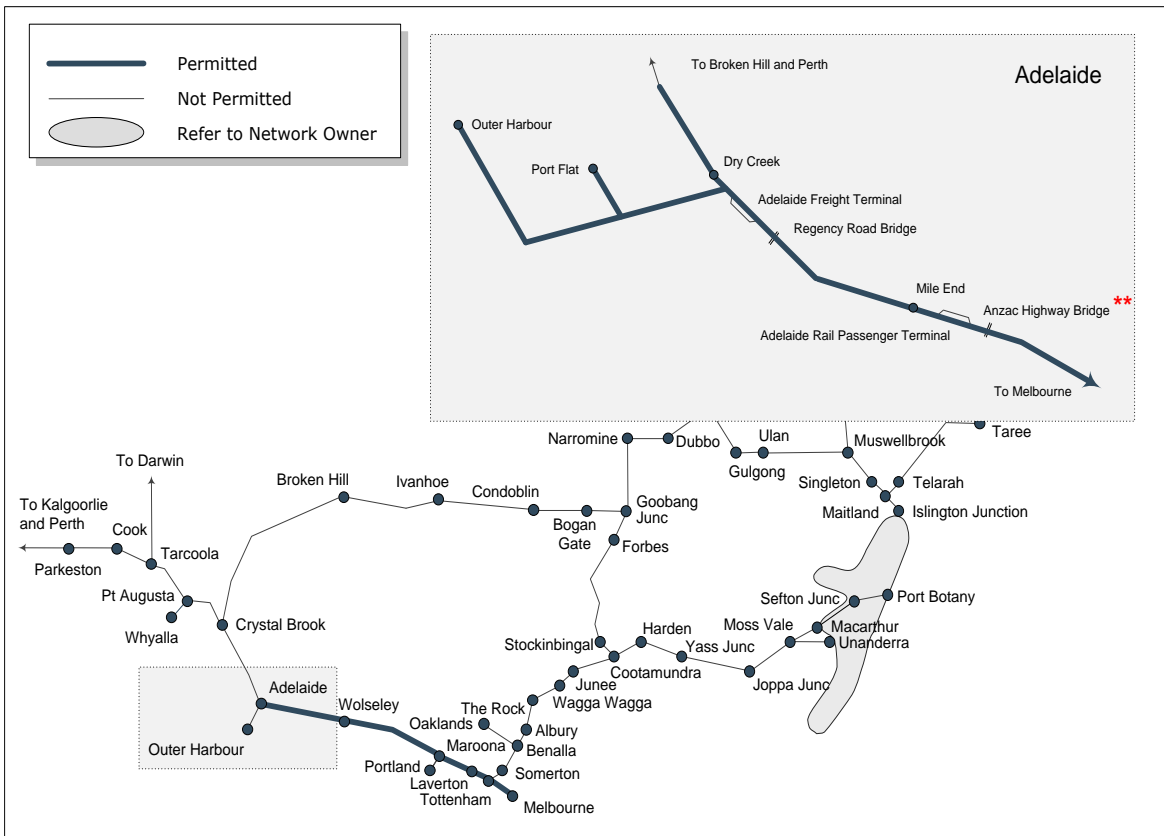

**Figure A2.11 – Maximum Container Loading from Maroona to Portland & Albion to Jacana**

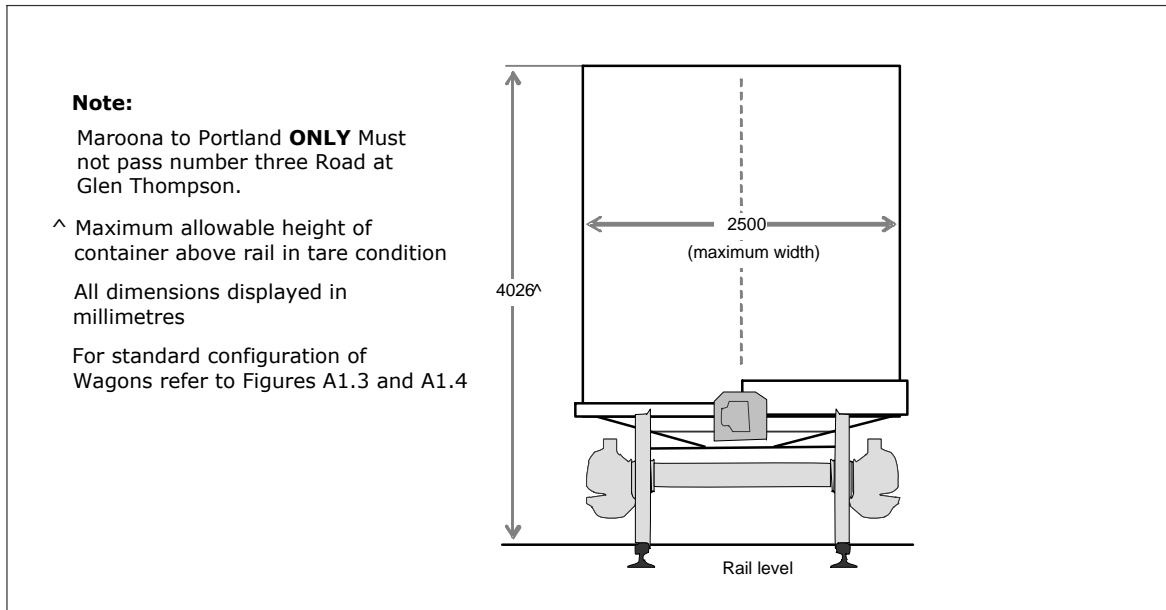

**Figure A2.11.1 – Diagram for Area of Operation for Figure A2.11**

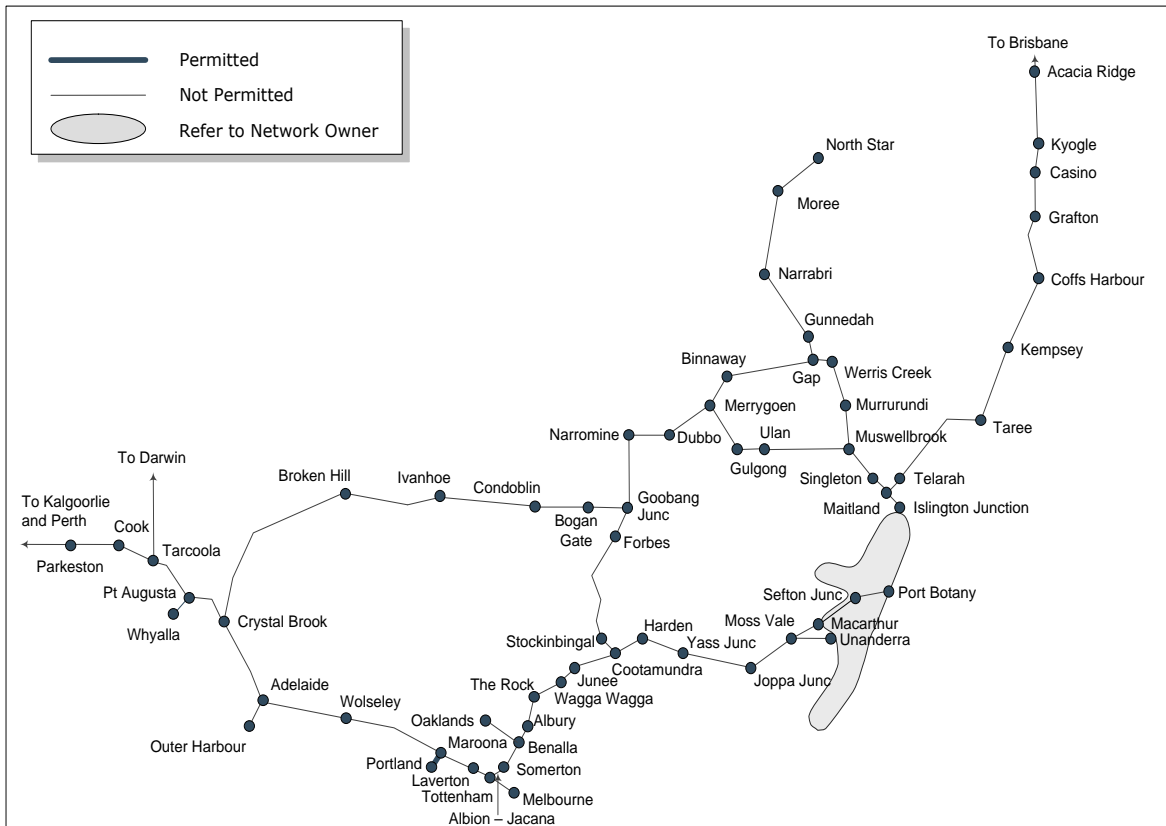
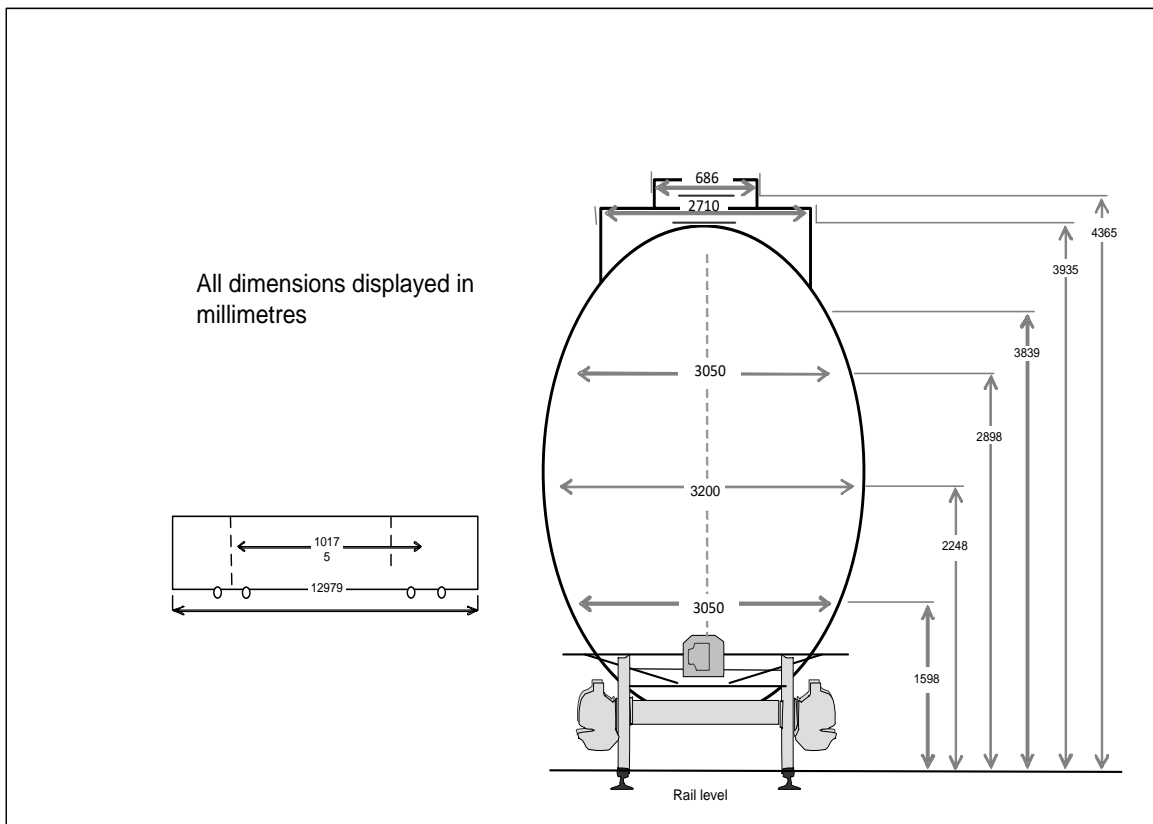
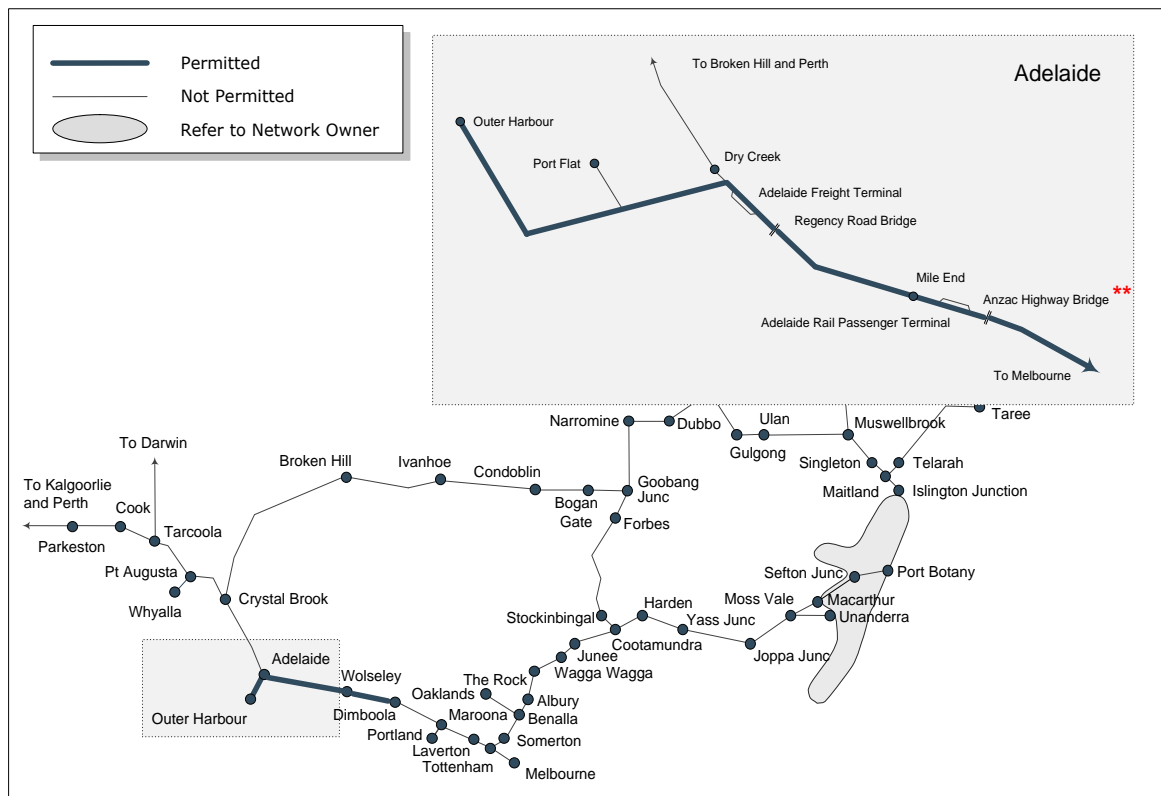

Figure A2.12 - Maximum Rolling Stock Outline for ex WA Wheathoppers (WW class)



Fig

re A2.12.1 – Areas of operation of ex WA Wheathoppers (WW class)



**Figure A2.13 - Maximum Loading Dimension for Motor Vehicles on Motorail Wagons from Anzac Highway Bridge (Adelaide) to Regency Road Bridge**

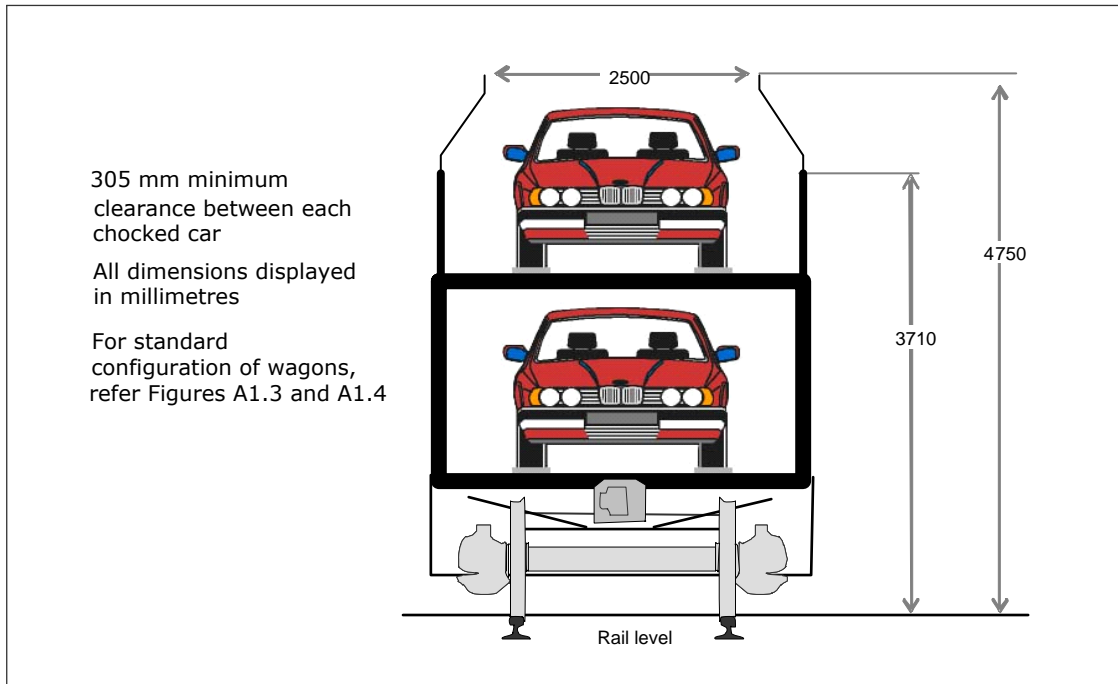

**Figure A2.13.1 – Location of Area of Operation of Figure A2.13**

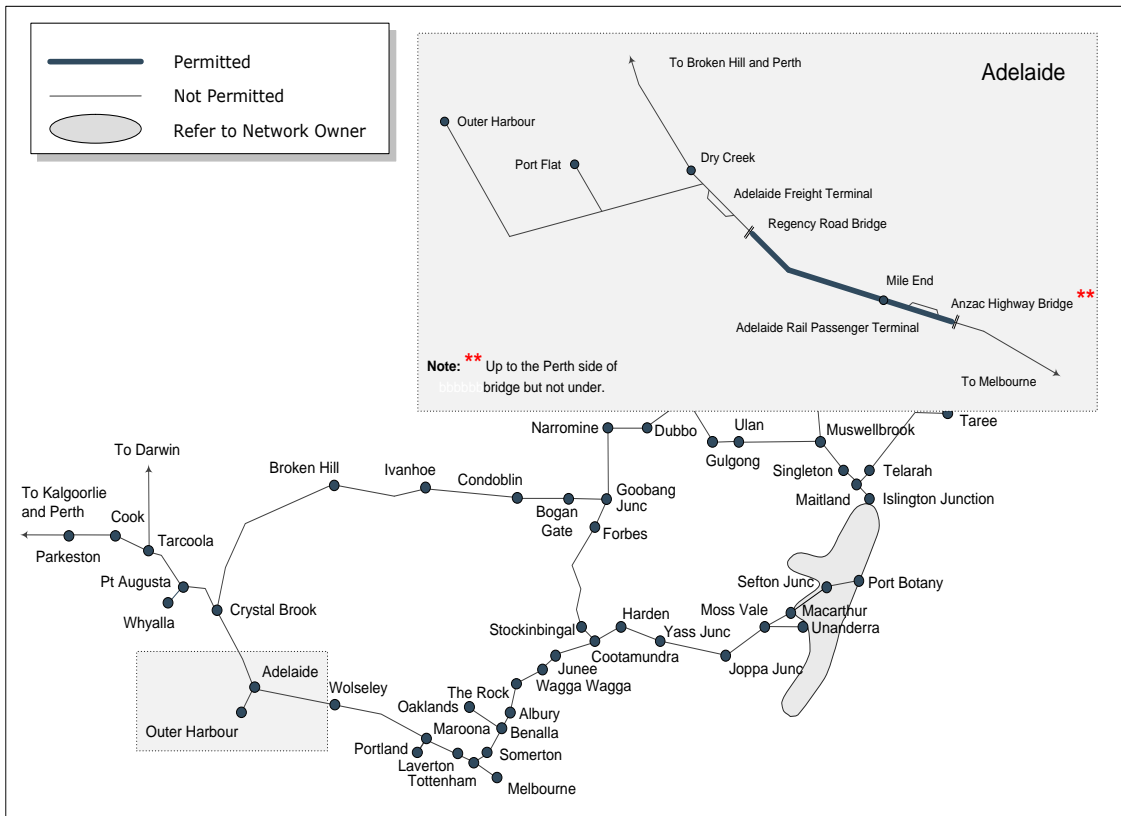

Operators shall have procedures in place to manage centre of gravity when vehicles are only loaded on the top deck.